

# MPPT SOLAR CHARGE CONTROLLER

LM6048

## User Manual

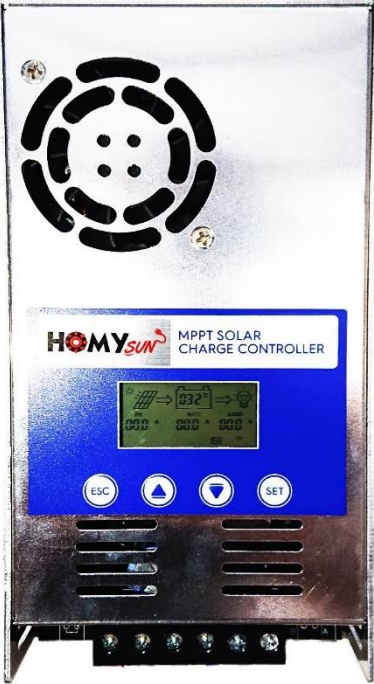

<b>Model</b>	LM6048-40	LM6048-60
<b>Battery voltage</b>	12V/24V/36V/48V	
<b>Max. solar panel voltage</b>	160V(25°C), 150V(-25°C)	
<b>Charging current</b>	40A	60A
<b>Discharging current</b>	20A	

Material Code: 20201003

Specification version  
number: V2.1

Dear users,

## Thanks for choosing Homysun product!

### Safety Instructions

1. As this controller deals with voltages that exceed the top limit for human safety, do not operate it before reading this manual carefully and completing safety operation training.
2. The controller has no internal components that need maintenance or service, thus do not attempt to disassemble or repair the controller.
3. Install the controller indoors, and avoid component exposure and water intrusion.
4. During operation, the radiator may reach a very high temperature, therefore install the controller at a place with good ventilation conditions.
5. It's recommended that a fuse or breaker be installed outside the controller.
6. Before installing and wiring the controller, make sure to disconnect the photovoltaic array and the fuse or breaker close to the battery terminals.
7. After installation, check if all connections are solid and reliable so as to avoid loose connections that may give rise to dangers caused by heat accumulation.

 **Warning:** means the operation in question is dangerous, and you should get properly prepared before proceeding.

 **Note:** means the operation in question may cause damage.

 **Tips:** means advice or instruction for the operator.

## 1. Product Introduction

### 1.1 Product Overview

This product can real-time detect the power of solar panels, and track the highest voltage current value (VI), make the system with maximum power output for battery charging. Used in off-grid solar pv system, coordinate the efforts of solar panels, battery, load, is the core of off-grid pv system control unit.

This product USES LCD operation state, running parameters and control parameters, etc. The user can through the button to refer to the various parameters, and can according to need to modify the control parameters to adapt to the different system requirements.

Controller inside has a comprehensive electronic fault self-test function and powerful protection function, can avoid to the greatest extent due to installation errors and system fault and cause the damage of the product components.

### 1.2 Product Features

- ◆ A built-in maximum power point tracking algorithm can significantly improve the energy utilization efficiency of photovoltaic systems, and raise the charging efficiency by 15% to 20% compared with the conventional PWM method.
- ◆ A combination of multiple tracking algorithms enables accurate tracking of the optimum working point on the I-V curve in an extremely short time.
- ◆ The product boasts an optimum MPPT tracking efficiency of up to 99.9%.
- ◆ Advanced digital power supply technologies raise the circuit's energy conversion efficiency to as high as 98%.
- ◆ Different charging program options including those for gel batteries, sealed batteries and open, batteries, customized ones, etc. are available.
- ◆ The controller features a limited current charging mode. When the solar panel power exceeds a certain level and the charging current is larger than the rated current, the controller will automatically lower the charging power and bring the charging current to the rated level.
- ◆ Instantaneous large current startup of capacitive loads is supported.
- ◆ Automatic recognition of battery voltage is supported.
- ◆ With defective LCD liquid crystal display, convenient user to identify system failure.
- ◆ The controller employs a built-in over-temperature protection mechanism. When temperature surpasses the set value, the charging current will decline in linear proportion to the temperature and discharging will be halted so as to curb the temperature rise of the controller, effectively keeping the controller from being damaged by overheat.
- ◆ Featuring a temperature compensation function, the controller can automatically adjust charging and discharging parameters in order to extend the battery's service life.
- ◆ 0 v lithium-ion batteries charging function.
- ◆ Use a metal shell, heat dissipation performance is better.
- ◆ Perfect electronic protection function.
- ◆ Solar panels charge high input voltage, reduces solar connection wire specifications, reduce the system cost.
- ◆ Can support Rs485 protocol model of choose and buy, meet different occasions communications needs.

### 1.3 Product characteristics

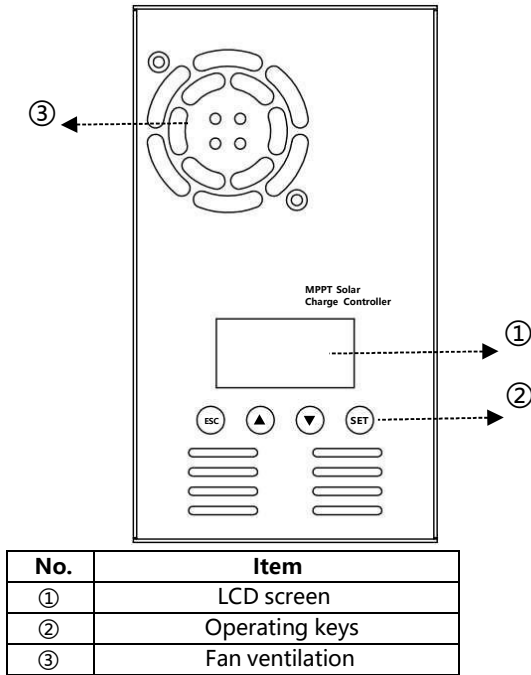

### 1.4 Introduction to Maximum Power Point Tracking Technology

Maximum Power Point Tracking (MPPT) is an advanced charging technology that enables the solar panel to output more power by adjusting the electric module's operating status. Due to the nonlinearity of solar arrays, there exists a maximum energy output point (maximum power point) on their curves. Unable to continuously lock onto this point to charge the battery, conventional controllers (employing switching and PWM charging technologies) can't get the most of the power from the solar panel. But a solar charge controller featuring MPPT technology can continuously track arrays' maximum power point so as to get the maximum amount of power to charge the battery.

Take a 12V system as an example. As the solar panel's peak voltage ( $V_{pp}$ ) is approximately 17V while the battery's voltage is around 12V, when charging with a conventional charge controller, the solar panel's voltage will stay at around 12V, failing to deliver the maximum input power. However, the MPPT controller can overcome the problem by adjusting the solar panel's input voltage and current in real time, realizing a maximum input power.

Compared with conventional PWM controllers, the MPPT controller can make the most of the solar panel's max. power and therefore provide larger charging current. Generally speaking, the latter can raise the energy utilization ratio by 15% to 20% in contrast with the former.

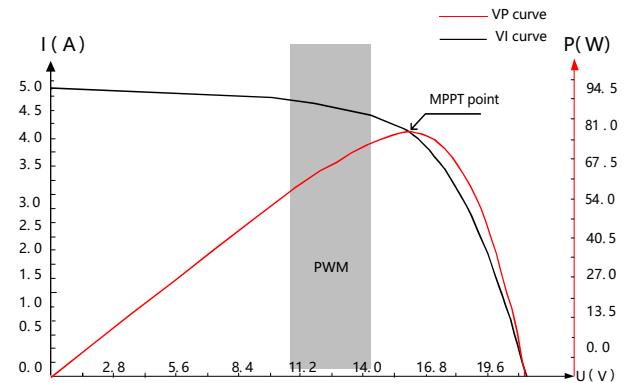

Fig. 1-2 Solar panel output characteristic curve

Meanwhile, due to changing ambient temperature and illumination conditions, the max. power point varies frequently, and our MPPT controller can adjust parameter settings according to the environmental conditions in real time, so as to always keep the system close to the max. operating point. The whole process is entirely automatic without the need of human intervention.

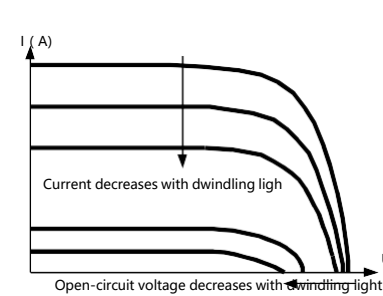

Fig. 1-3 Relation between solar panel output characteristics and illumination

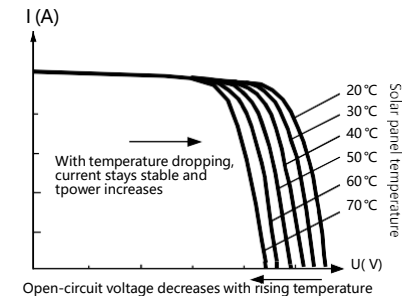

Fig. 1-4 Relation between solar panel output characteristics and temperature

## 2. Product Installation

### 2.1 Installation Precautions

- Be very careful when installing the battery. For open lead-acid batteries, wear a pair of goggles during installation, and in case of contact with battery acid, flush with water immediately.
- In order to prevent the battery from being short-circuited, no metal objects shall be placed near the battery.
- Acid gas may be generated during battery charging, thus make sure the ambient environment is well ventilated.
- Keep the battery away from fire sparks, as the battery may produce flammable gas.
- when needs arise to move things, avoid wire swaying so as to keep connections from loosening. sunlight and rain water intrusion.
- Loose connections or corroded wire may cause excessive heat generation which may further melt the wire's insulation layer and burn surrounding materials, and even cause a fire, therefore make sure all connections are tightened securely. Wires had better be fixed properly with ties, and when needs arise to move things, avoid wire swaying so as to keep connections from loosening.
- When connecting the system, the output terminals' voltage may exceed the top limit for human, safety. If operation needs to be done, be sure to use insulation tools and keep hands dry.
- The wiring terminals on the controller can be connected with a single battery or a pack of batteries. Following descriptions in this manual apply to systems employing either a single battery or a pack of batteries.
- Follow the safety advice given by the battery manufacturer.
- When selecting connection wires for the system, follow the criterion that the current density is not larger than 4A/mm<sup>2</sup>.
- Connect the controller's earth terminal to the ground.

### 2.2 Wiring Specifications

Wiring and installation methods must comply with national and local electrical specifications. The wiring specifications of the battery and loads must be selected according to rated currents, and see the following table for wiring specifications:

Model	Rated charging current	Rated discharging current	Battery wire diameter (mm <sup>2</sup> )	Load wire diameter (mm <sup>2</sup> )
LM6048-40	40A	20A	6mm <sup>2</sup>	5 mm <sup>2</sup>
LM6048-60	60A	20A	12mm <sup>2</sup>	5 mm <sup>2</sup>

### 2.3 Installation and Wiring

**Warning:** risk of explosion! Never install the controller and an open battery in the same enclosed space! Nor shall the controller be installed in an enclosed space where battery gas may accumulate.

**Warning:** danger of high voltage! Photovoltaic arrays may produce a very high open-circuit voltage. Open the breaker or fuse before wiring, and be very careful during the wiring process.

**Note:** when installing the controller, make sure that enough air flows through the controller's radiator, and leave at least 150 mm of space both above and below the controller so as to ensure natural convection for heat dissipation. If the controller is installed in an enclosed box, make sure the box delivers reliable heat dissipation.

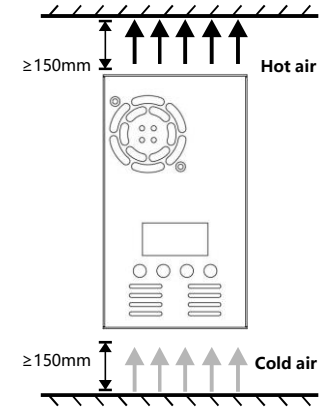

Fig. 2.1 Installation and heat dissipation

#### Step 1: choose the installation site

Do not install the controller at a place that is subject to direct sunlight, high temperature or water intrusion, and make sure the ambient environment is well ventilated.

#### Step 2: fit screws in

To put the controller in the first place, then the pen on the installation location to do mark, in four mark drill size suitable mounting holes.

#### Step 3: fix the controller

Aim the controller four installed drilled hole screws in advance.

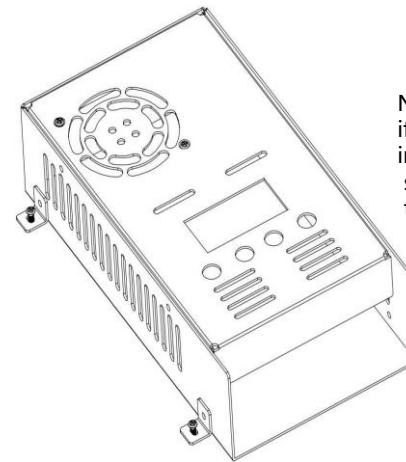

Note: please only use the screw, we offer if you use other screw, it may damage the internal PCB. Please use proper torque to screw into the shell, because of the strong torque can damage internal PCB.

#### Step 4: wire

In order to install security, by the cell. Solar panels again. Finally the load. Please note that all wiring of the positive and negative don't answer the reverse. When wiring, please follow the "+", first after "-".

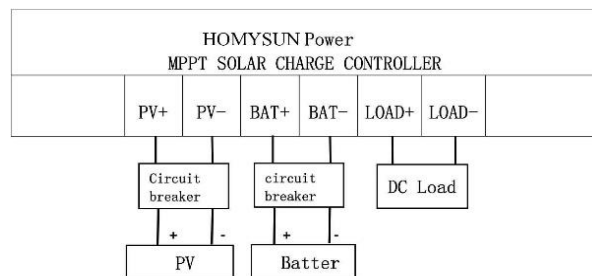

#### ① Connect power line

**⚠ Warning:** the risk of electric shock! We strongly recommend that side, load and the photovoltaic array and battery end connected to the fuse or circuit breaker to prevent shock hazard during connection or wrong operation and before connection and make sure the fuse or circuit breaker is in off state.

**⚠ Warning:** high voltage danger! Photovoltaic (pv) array may lead to high open circuit voltage, connection should be disconnected before circuit breaker or fuse, must be careful in the process of wiring.

**⚠ Warning:** the danger of explosion. Battery positive and negative extreme son and across the electrodes connected to the wire once a short circuit will cause fire or explosion. Please be careful operation.

#### ② Put through power supply

When all the power line connection is firm and reliable, again, check the wiring is correct, is negative if the. After the confirmation and correct fuse or circuit breaker connected to battery, LCD screen display. If there is no display, please check whether the circuit is again immediately cut off the fuse or circuit breaker connection is correct.

If battery power is normal, then connect panels, if the sunshine, the controller's screen flicker and began to the battery charging charging instructions.

When batteries and photovoltaic connection, and then will load fuse or circuit breaker connected, manual mode can be used to test the load at this time of opening and closing is normal. See the load working mode and operation.

**⚠ Warning:** when the controller under normal charging status, such as controller dc load disconnect the battery will have an impact, serious can damage the load.

**⚠ Warning:** the battery connection polarity reverse operation, can damage the internal components of the controller.

#### Note:

1) Insurance battery installation position should be close to the battery terminal, suggest installation distance less than 150 mm.

2) Controller in the case of not to connect to a remote temperature sensor battery temperature is 25 °C a fixed value.

3) If the system of inverter, the inverter directly connected to the battery, please, do not connected to the load end of the controller.

### 3. Product operation and display

#### 3.1 keystrokes

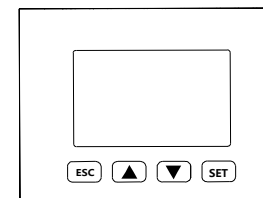

ESC	Switch load (manual switch load);Settings interface to exit the Settings;
▲	Main interface page up parameters;Set the mode parameters and;
▼	Main interface page look down parameters;Setting up the mode parameters;
SET	Enter the Settings/confirm/save, 10 s keystrokes to exit the setup;

#### 3.2 And the main interface will start LCD display

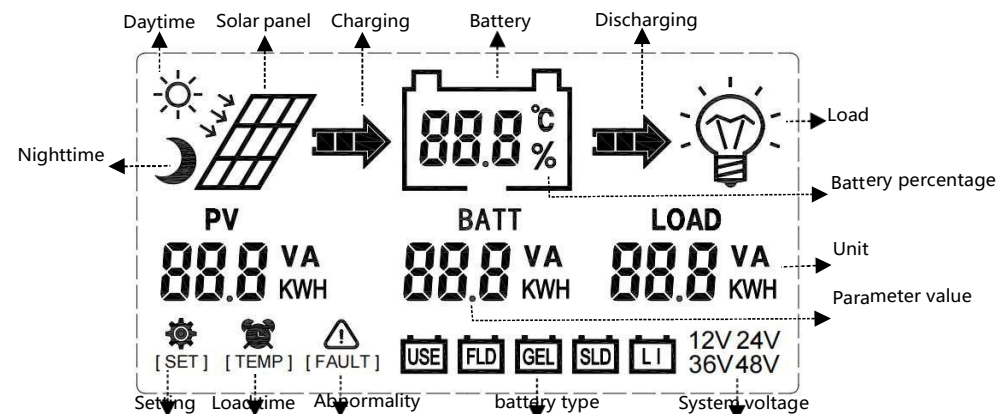

### 3.3 Main interface display is introduced

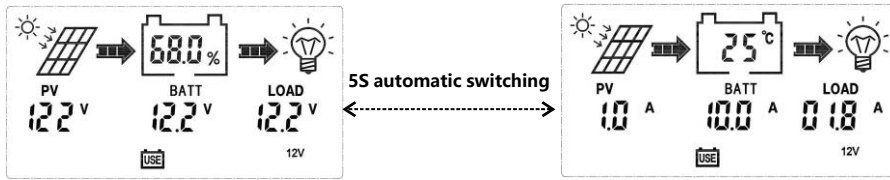

**Note:** under the main interface, the 5 s automatic switching cycle display detection parameters.

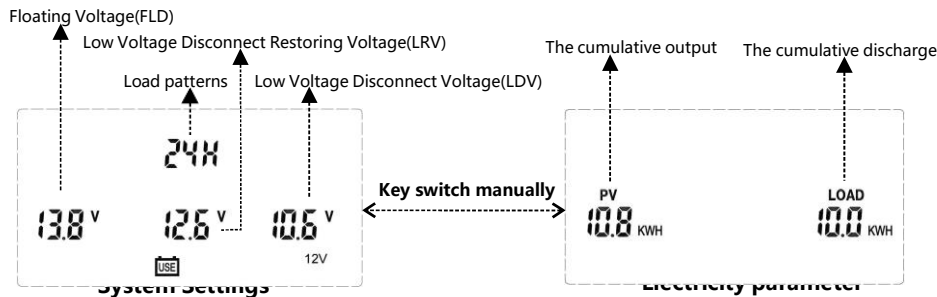

**Note:** under the main interface, can be obtained by manual switch display system set up and down key parameters and power parameters. 5 s no button operation automatically switches the main interface.

### 3.4 Load model is introduced

This controller has three kinds of load working mode, model reference is as follows:

Model	Describe
Light control mode (01H~23H)	When there is no sunlight, panels voltage is lower than the electric voltage, the controller automatically according to the set time open load operation mode. When the sun appears, panels voltage higher than the electric voltage, the controller automatically shut down load.
Normally closed mode(0H)	On electric load has remained closed, and no matter whether during the day or night. This pattern is used in some special load situations or debugging use.
Normally open mode(24H)	Electricity load keep output state, this model is suitable for power supply load need to 24 hours.

**Note:** the above three models can be through the switch button to open or close the load, the second day automatic recovery operation controller model has been set.

### 3.5 System parameter Settings

**Restore the factory value:** under the main interface, press SET and ESC button for 5 seconds at the same time, can SET the charging and load value SET back to the factory.

**Enter the Settings interface:** On the main page, press SET button to enter setup interface display " [SET] " normally on instructions, into a state controller Settings.

**Battery type:** Under the Settings interface, through the short press SET key, select SET battery type column " [USE] [FLD] [GEL] [SLD] [LI] ", the corresponding cell types will flash, press the up and down key can choose need battery types, 10S without keystrokes to exit the save Settings of parameters automatically.



**Charging parameter Settings:** Under the Settings interface, through the short press SET key, select Settings section. The selected parameters after parameters automatically. Note: set the cell type in the " [FLD] [GEL] [SLD] " type, the charging parameters can not be set.

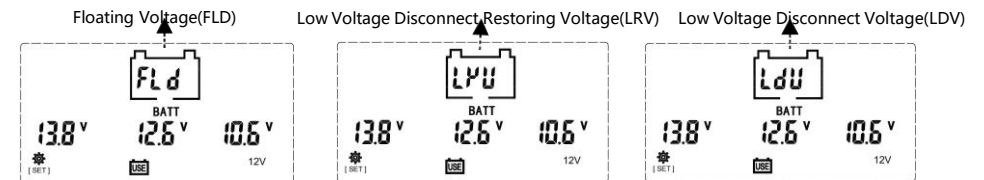

**System voltage Settings:** Under the Settings interface, through the short press SET key, select " 12V 24V 36V 48V " SET up the system voltage type column, the corresponding system voltage instability, press the up and down key can choose need battery system voltage level, 10S without keystrokes to exit the save Settings of parameters automatically. Note: choose 24 v system, charging parameters for 12 v 2 times. Select 36 v system, charging parameters for 12 v 3 times. Choose 48 v system, charging parameters for the 12 v 4 times.

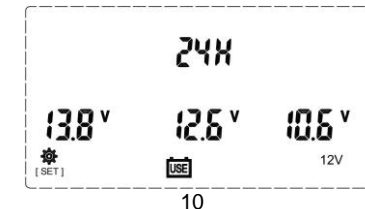

**Load Settings:** under the Settings interface, through the short press SET key, SET load timing type column " [TEMP] ", selected parameters after the cursor blink press up and down keys to adjust parameters, 10S without keystrokes to exit the save Settings of parameters automatically.



**⚠ Note:** after system voltage setting, power supply has to be switch off and then on again, otherwise the system may work under an abnormal system voltage.

The controller enables users to customize the parameters according to the actual conditions, but parameter setting must be done under the guidance of a professional person, or else faulty parameter settings may render the system not able to function normally. For details about parameter settings, see table 3

Parameter setting cross-reference table			
No.	Description	Parameter range	Default setting
1	Battery type	User/flooded/Sealed/Gel/LI	Sealed
2	System voltage	12V/24V/36V/48V	AUTO
3	Floating charging voltage	10.0 ~ 20.0V	13.8V
4	Over-discharge recovery voltage	9.0 ~ 20.0V	12.6V
5	Over-discharge voltage	9.0 ~ 20.0V	10.6V

Table 3

### 3.6 Abnormal display and alarm

When a failure occurs, the control system of a fault indicator icon display " [FAULT] " .

	Solar panels, solar panels overvoltage.
	Battery boxes flashing, system parameter setting error.
	LED flashing, load flow or short circuit protection.

## 4. Product protection function and system maintenance

### 4.1 Protection function is introduced

- ◆ **Waterproof**  
Waterproof level: IP21
- ◆ **Input power limiting protection**  
When the solar panel power exceeds the rated power, the controller will limit the solar panel power under the rated power so as to prevent excessively large currents from damaging the controller and enter into current-limited charging.
- ◆ **Photovoltaic input side too high voltage protection**  
If the voltage on the photovoltaic array input side is too high, the controller will automatically cut off photovoltaic input.
- ◆ **Photovoltaic input side short-circuit protection**  
If the photovoltaic input side gets short-circuited, the controller will halt charging, and when the short circuit issue gets cleared, charging will automatically resume.
- ◆ **Photovoltaic input reverse-connection protection**  
When the photovoltaic array is reversely connected, the controller will not break down, and when the connection problem gets solved, normal operation will resume.
- ◆ **Load short-circuit protection**  
To load short circuit timely fast protection and open automatically after a certain time delay trying to load. When a load short circuit, can be manually remove load short circuit.
- ◆ **Reverse charging protection at night**  
This protection function can effectively prevent the battery from discharging through the solar panel at night.
- ◆ **TVS lighting protection.**
- ◆ **Over-temperature protection.**  
When the controller temperature exceeds the set value, it will decrease the charging power or halt charging.

### 4.2 System Maintenance

- ◆ In order to always keep the controller's performance at its optimum level, we recommend that the following items be checked twice a year.
- ◆ Make sure the airflow around the controller is not blocked and clear away any dirt or debris on the radiator.
- ◆ Check if any exposed wire gets its insulation undermined due to exposure to sunlight, friction with other adjacent objects, dry rot, damage by insects or rodents, etc. Repair or replace those affected when necessary.
- ◆ Validation screen is consistent with the equipment operation. Please note that any fault or error according to take corrective action when necessary.
- ◆ Check all wiring terminals for any sign of corrosion, insulation damage, overheat, combustion/ discoloration, and tighten the terminal screws firmly.
- ◆ If the lightning arrester has lost its efficacy, replace it with a new one timely to prevent the controller and even other devices owned by the user from being damaged by lightening.

**⚠ Warning:** risk of electric shock! Before carrying out the above checkings or operations, always make sure all power supplies of the controller have been cut off!

## 5. Product specifications

### 5.1 Electrical parameters

Parameter	Value	
Model	LM6048-40	LM6048-60
System voltage	12V/24V/36V/48V/Auto	
No-load loss	≤0.4W	
Max. solar input voltage	160V(25°C) 150V(-25°C)	
Battery voltage	9~70V	
Max. power point voltage range	Battery voltage+2V~ 120V	
Rated charging current	40A	60A
Rated load current	20A	
Max. photovoltaic system input power	480W/12V 960W/24V 1440W/36V 1920W/48V	720W/12V 1440W/24V 2160W/36V 2880W/48V
Conversion efficiency	≤98%	
MPPT tracking efficiency	> 99%	
Temperature compensation factor	-2mv/°C/2V (default)	
Operating temperature	-10°C ~+65°C	
Waterproof level	Ip21	
Net weight	1.15Kg	1.25Kg
Gross weight	1.25Kg	1.35Kg
Electromagnetic compatibility	Accord to EN61000, EN55022, EN55024	
Communication method	Rs485(Need to choose and buy)	
Altitude	≤ 3000m	
Product dimensions	214*115*50mm	

### 5.2 Battery Type Default Parameters

Each type of battery parameter table					
Setting Voltage Battery Type	Gelled Lead-Acid Battery(GEL)	Sealed Lead-Acid Battery(SLD)	Opening Lead-Acid Battery(FLD)	User	LI Battery
System Volt	Auto	Auto	Auto	Auto/12/24/36/48	12/24/36/48
Equalizing Voltage(EQU)	14.2V	14.6V	14.8V	---	---
Boost Voltage(BST)	14.2V	14.4V	14.6V	---	---
Floating Voltage(FLD)	13.8V	13.8V	13.8V	Defined by GEL	Defined by GEL
Low Voltage Disconnect Restoring Voltage(LRV)	12.6V	12.6V	12.6V	Defined by GEL	Defined by GEL
Low Voltage Disconnect Voltage(LDV)	11.1V	11.1V	11.1V	Defined by GEL	Defined by GEL

Use the battery for custom battery types, system default parameters and colloid lead-acid storage battery voltage is consistent, when the battery charge and discharge parameters must follow the following logic: FLD>LRV >LDV;

