

INVERTER

CW100

Vector Compacted Series

User Manual V1.0

Thank you for purchasing the VFD.

Read and understand the manual before use and forward the manual to the end user.

MANUAL

Before use, please read **【the safety precautions】** carefully.

Please keep this manual carefully for consulting if necessary. If you have any doubt, please contact our customer service or technical support, our professional will serve you wholeheartedly.

This manual provides information about CW100 series frequency inverters, including:

- ◆ Safety information and precautions
- ◆ Installation and inspection
- ◆ Wiring instruction
- ◆ Operation instruction
- ◆ Communication protocol specification
- ◆ Maintenance and troubleshooting

This manual is suitable for the following users

- ◆ System design and selection personnel
- ◆ Installation or wiring personnel
- ◆ Debugging personnel
- ◆ Maintenance personnel

Contents

Chapter 1 Safety Information and Precautions.....	3
---	---

MANUAL

1.1 Safety Information and Precautions.....	3
1.2 Operation Precautions.....	3
Chapter 2 Product Information.....	5
2.1 Designation Rules.....	5
2.2 Technical Specification.....	5
2.3 Peripheral Electrical Devices and System Configuration.....	6
Chapter 3 Installation Guide.....	7
3.1 Product Size Diagram.....	7
3.2 Product Installation Diagram.....	7
Chapter 4 Wiring Instructions.....	9
4.1 Interface and Terminal Instructions.....	9
4.1.1 Main Circuit Terminals.....	9
4.1.2 Control Circuit Terminals.....	9
4.2 Reference Wiring Diagram.....	10
Chapter 5 Operation Panel.....	12
5.1 Appearance Diagram.....	12
5.2 Indicator Light Instruction.....	12
5.3 Key Instruction.....	12
Chapter 6 Function Parameter Table.....	13
Chapter 7 Maintenance and Troubleshooting.....	40
7.1 Fault Description.....	40
7.2 Troubleshooting List.....	40
7.3 Faults and Solutions.....	43
7.4 Braking Resistance Specification.....	45

MANUAL

Chapter 1 Safety Information and Precautions

1.1 Safety Information and Precautions

- ◆ It is forbidden to use the device near water, corrosive gas, combustible gas, inflammable and explosive materials, otherwise it will cause electric shock, combustion or explosion.
- ◆ Prohibit the use of this device in places that restrict or prohibit the use of this device, otherwise it may lead to an accident.
- ◆ The high voltage of the frequency inverter will remain for a period of time after the power is off. Please do not remove the wire or touch the terminal within 3 minutes of power off, otherwise there is a danger of electric shock.
- ◆ Make sure that the earth terminal of the inverter is grounded reliably. Otherwise, there is a risk of electric shock.
- ◆ Do not contact with the internal components and circuits of the frequency inverter. Otherwise, there is a risk of electric shock.
- ◆ It is forbidden to modify the internal parts or circuits of the frequency inverter.
- ◆ This series of inverters are used to control ordinary asynchronous motor and frequency conversion asynchronous motor, not for single-phase motor and other applications.
- ◆ Do not use damaged inverter, otherwise it may cause an accident.
- ◆ Please select a safe position to install servo inverter to prevent direct exposure to high temperature and sunlight, avoid dampness, splash of water droplets and erosion of various oils, avoid metal powder or iron chips into the inverter.

1.2 Operation Precautions

- ◆ It must be connected, installed and operated by a professional.
- ◆ Wiring shall not be connected when the power supply is turned on, otherwise it may cause electrical shock or injury to personnel.
- ◆ Terminal voltage and polarity must be applied to prevent damage to equipment or injury to personnel.
- ◆ Please do not pass the power line and signal line through the same pipe, and do not tie them together.
- ◆ Frequency inverter must be matched with the asynchronous motor, and maintain good heat-dissipation conditions.
- ◆ Do not touch the heat sink and brake resistor of the inverter while running, otherwise

MANUAL

you may burn.

- ◆ Please do not switch power supply frequently, it is best to control the interval of more than 1 minute.
- ◆ The AC power supply is prohibited from being connected to the output terminals U, V, W of the frequency inverter, otherwise the internal damage of the frequency inverter can be caused.

MANUAL

Chaper 2 Product Information

Upon receipt of the goods, please examine the following items carefully:

- ◆ Whether the type of frequency inverter is correct.
- ◆ Whether the appearance is damaged

2.1 Designation Rules

Model Number Instruction

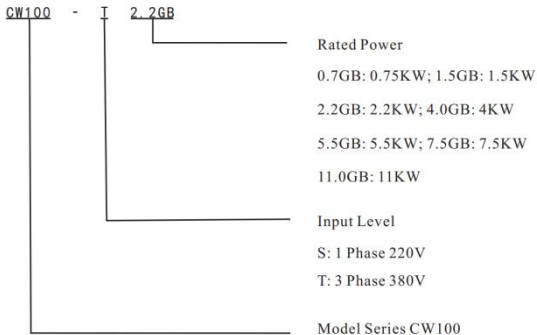

2.2 Technical specifications

Model	Power Supply Capacity KVA	Input Current A	Output Current A	Adaptable Motor	
				kW	HP
One phase power supply: 220V, 50HZ/60HZ					
CW100-S0.7GB	1.5	8.2	4.0	0.75	1

MANUAL

CW100-S1.5GB	3.0	14.0	7.0	1.5	2
CW100-S2.2GB	4.0	23.0	9.6	2.2	3
CW100_S4.0GB	5.9	25.5	17	4.0	5
Three phase power supply: 380V, 50HZ/60HZ					
CW100-T0.7GB	1.5	3.4	2.1	0.75	1
CW100-T1.5GB	3.0	5.0	3.8	1.5	2
CW100-T2.2GB	4.0	5.8	5.1	2.2	3
CW100-T4.0GB	5.9	10.5	9.0	4.0	5
CW100-T5.5GB	8.9	14.6	13.0	5.5	7.5
CW100-T7.5GB	11.0	20.5	17.0	7.5	10
CW100-T11.0GB	17.0	26.0	25.0	11.0	15
One phase 220V input, Three phase 380V output, 50HZ/60HZ					
CW100-T0.7GB (220Vto380V)	1.5	7.5	2.1	0.75	1
CW100-T1.5GB (220Vto380V)	3.0	11	3.8	1.5	2
CW100-T2.2GB (220Vto380V)	4.0	16	5.1	2.2	3
CW100-T4.0GB (220Vto380V)	5.9	27	9.0	4.0	5
CW100-T5.5GB (220Vto380V)	8.9	36	13.0	5.5	7.5

2.3 Installation Environment Requirements

Ingress Protection Grade — IP20

Installation Height — The maximum is 1000 m (3280 ft) at sea level. If the installation height is above this value, the current should be reduced by 1.2% for every 10 m (328 ft) increase in height.

Ambient temperature at running — 0~40°C (32~104 °F)

Temperature at storage — -20~55°C(-4~131 °F)

Temperature at transportation — -20~60°C(-4~140 °F)

Air Humidity

At running — 5%~85%, no condensation or freezing

At storage — 5%~95%

MANUAL

Chapter 3 Installation Guide

3.1 Installation Dimension Diagram of Outer panel

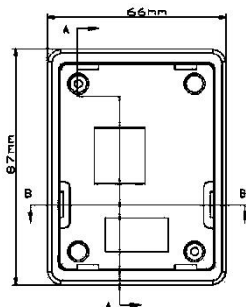

3.2 Product Dimension Diagram, Installation Diagram

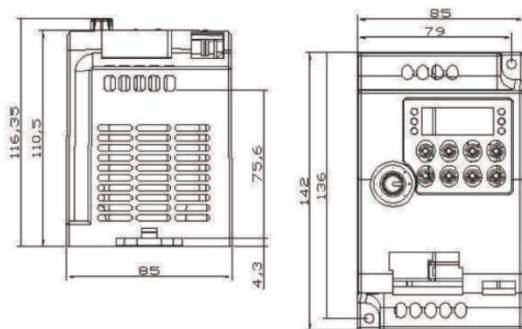

CW100-0.75KW-2.2KW

MANUAL

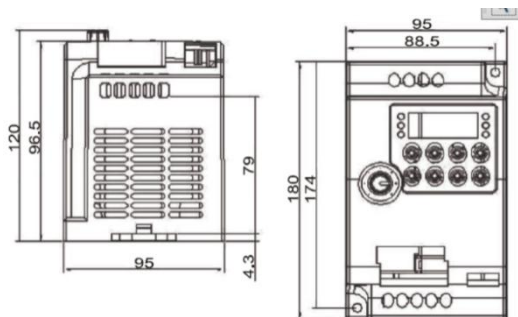

CW100-4KW-5.5KW

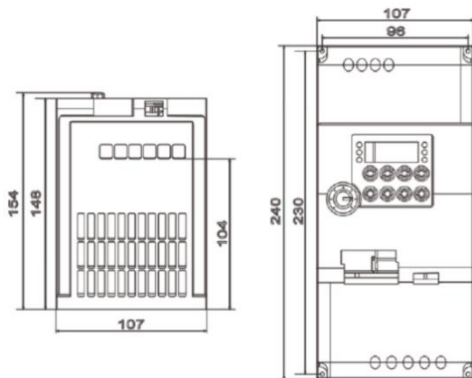

CW100-7.5KW-11.0KW

MANUAL

Chapter 4 Wiring Instructions

4.1 Interface and Terminal Instructions

4.1.1 Main Circuit Terminal

Table 4-1 Interface and Terminal Function Description

Terminal	Name	Function Description
R、S、T	Ac power input terminal	Connect the input three-phase AC power supply, 220V single-phase connect R, T
P+、PB	Brake resistor terminal	Connect brake resistor
U、V、W	Output terminal	Connect three-phase motor
	Earth terminal	Grounding Connection

4.1.2 Control Circuit Terminal

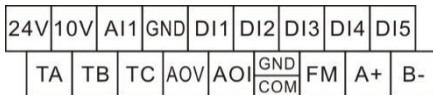

Sketch 4-1 Control Circuit Terminal Diagram

Table 4-2 CW100 Description of Control Circuit Terminals

Item	Terminal	Name	Function Description
Power supply	10V-GND	External 10V power supply	1k Ω ~5k Ω Provide +10 V power supply to external unit. Generally, it provides power supply to external potentiometer with resistance range of 1~5 k Ω . Maximum output current: 10 mA
	24V-GND	External 24V power supply	Provide +24 V power supply to external unit. Generally, it provides power supply to DI/DO terminals and external sensors. Maximum output current: 200 mA
Analog input	A11-GND	Analog input terminal 1	Input range: DC 0V~10V/0mA~20mA, decided by P4-39. Resistance input: 22 k Ω (voltage input), 500 Ω (current input)
Digital input	DI1-GND	Digital input 1	Resistance input: 1 k Ω
	DI2-GND	Digital input 2	

MANUAL

	DI3-GND	Digital input 3	Voltage range for level input: 5–30V
	DI4-GND	Digital input 4	
	DI5-GND	High-speed pulse input terminal	Besides features of DI1–DI4, it can be used for high-speed pulse input. Maximum input frequency: 20 kHz
Analog output	AOV-GND	Analog output	Output voltage range: 0–10 V Output current range: 0–20 mA
	AOI-GND		
Digital output	FM-GND	High-speed pulse output	It is limited by F5-00 (FM terminal output mode selection). As high-speed pulse output, the maximum frequency hits 20 kHz. As open-collector output, its specification is the same as that of DO1
	TA-TB	NC terminal	Contact driving capacity: 250Vac, 3A, COS ϕ =0.4 30Vdc, 1A
	TA-TC	NO terminal	
Communication terminal	A+-B-	485 communication terminal	MODBUS-RTU protocol communication input and output signal terminals

4.2 Wiring Diagram

MANUAL

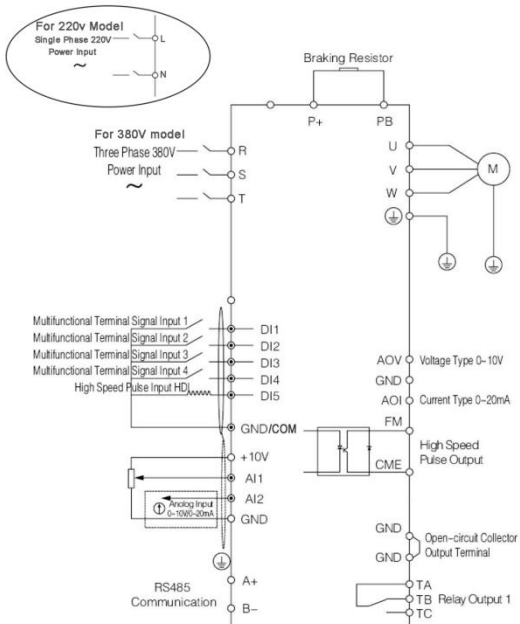

MANUAL

Chapter 5 Operation Panel

5.1 Appearance Diagram



5.2 Description of Indicators

- 1) RUN: ON indicates that the AC drive is in the running state, and OFF indicates that the AC drive is in the stop state.
- 2) LOC: It indicates whether the AC drive is operated by means of operation panel, terminals or communication.
- 3) F/R: ON indicates reverse rotation.
- 4) Hz、A、V: Unit Indicators. It indicates the temporary display unit, which has the following units:
Hz: unit of frequency A: unit of current V: unit of voltage
Hz + A: unit of rotational speed A + V : % percentage

5.3 Description of Keys on the Operation Panel

Key	Name	Function
PROG	Programming	Enter or exit Level I menu.
M-FUN	Multifunction Selection	Function switch selection. It can be defined as a command source, or as a fast direction switch, according to P7-01.
▲	Increment	Increase data or function code.
▼	Decrement	Decrease data or function code.
SHIFT	Shift	Select the displayed parameters in turn in the stop or running state, and select the digit to be modified when modifying parameters.
ENTER	Confirm	Enter the menu interfaces level by level, and confirm the parameter setting.
RUN	Run	Start the AC drive in the operation panel control mode.
STOP	Stop	Stop the AC drive when it is in the running state and perform the reset operation when it is in the fault state. The functions of this key are restricted in P7-02.

MANUAL

Chapter 6 Function Code Table

6.1 Brief introduction of function code

If PP-00 is set to a non-zero number, parameter protection is enabled. You must enter the correct user password to enter the menu. To cancel the password protection function, enter with password and set FP-00 to 0.

Group P and Group A are standard function parameters. Group U is the monitoring function parameters.

The symbols in the function code table are described as follows:

“☆”: The parameter can be modified when the AC drive is in either stop or running state.;

“★”: The parameter cannot be modified when the AC drive is in the running state.;

“●”: The parameter is the actually measured value and cannot be modified.;

“*”: The parameter is factory parameter and can be set only by the manufacturer.

Table 6-1 Standard Function Parameters

Function Code	Parameter Name	Setting Range	Default	Property
P0 Standard Function Parameters				
P0-01	Motor control mode	0: Sensorless flux vector control (SFVC) 2: V/F control	2	★
P0-02	Command source selection	0: Operation panel control (LED off) 1: Terminal control (LED on) 2: Communication control (LED blinking)	0	☆
P0-03	Main frequency source X selection	0: Digital setting (preset frequency P0-08, press UP/DOWN to modify, non-retentive at power failure) 1: Digital setting (preset frequency P0-08, press UP/DOWN to modify, retentive at power failure) 2: AI1 3: AI2 local potentiometer 4: Panel potentiometer external keyboard potentiometer 5: HDI pulse setting (DI5) 6: Multi-command 7: Simple PLC 8: PID 9: Communication setting	3	★
P0-04	Auxiliary frequency source Y selection	The same as P0-03 (Main frequency source X selection)	0	★
P0-05	Selection of Y range of auxiliary frequency source in superposition	0: Relative to maximum frequency 1: Relative to main frequency X	0	☆
P0-06	Selection of Y range of auxiliary frequency source in superposition	0% ~ 150%	100%	☆

MANUAL

Function Code	Parameter Name	Setting Range	Default	Property
P0-07	Frequency source superposition selection	Unit's digit (Frequency source selection) 0: Main frequency source X 1: X and Y operation (operation relationship determined by ten's digit) 2: Switchover between X and Y 3: Switchover between X and "X and Y operation" 4: Switchover between Y and "X and Y operation" Ten's digit (X and Y operation relationship) 0: X+Y 1: X-Y 2: Maximum 3: Minimum	00	☆
P0-08	Preset frequency	0.00Hz ~ maximum frequency (P0-10)	50.00Hz	☆
P0-09	Rotation direction	0: Same direction 1: Reverse direction	0	☆
P0-10	Maximum frequency	5.00Hz ~ 500.00Hz For setting max frequency above 320Hz, please set P0-22=1 (for below 320Hz, P0-22 can be 2) & also P0-10, P0-12, P1-04.	50.00Hz	★
P0-11	Source of frequency upper limit	0: Set by P0-12 1: AI1 2: AI2 local potentiometer 3: AI3 panel potentiometer external keyboard potentiometer 4: HDI pulse setting 5: Communication setting	0	★
P0-12	Frequency upper limit	Frequency lower limit (P0-14) to maximum frequency (P0-10)	50.00Hz	☆
P0-13	Frequency upper limit offset	0.00Hz ~ maximum frequency P0-10	0.00Hz	☆
P0-14	Frequency lower limit	0.00Hz ~ frequency upper limit P0-12	0.00Hz	☆
P0-15	Carrier frequency	2.0kHz ~ 8.0kHz	Model dependent	☆
P0-16	Carrier frequency adjustment with temperature	0: No 1: Yes	1	☆
P0-17	Acceleration time 1	0.00s ~ 650.00s(P0-19=2) 0.0s ~ 6500.0s(P0-19=1) 0s ~ 65000s(P0-19=0)	Model dependent	☆
P0-18	Deceleration time 1	0.00s ~ 650.00s(P0-19=2) 0.0s ~ 6500.0s(P0-19=1) 0s ~ 65000s(P0-19=0)	Model dependent	☆

MANUAL

Function Code	Parameter Name	Setting Range	Default	Property
P0-19	Acceleration/Deceleration time unit	0: 1s 1: 0.1s 2: 0.01s	1	★
P0-21	Frequency offset of auxiliary frequency source for X and Y operation	0.00Hz ~ maximum frequency P0-10	0.00Hz	☆
P0-22	Frequency reference resolution	1: 0.1Hz 2: 0.01Hz	2	★
P0-23	Retentive of digital setting frequency upon power failure	0: Not retentive 1: Retentive	1	☆
P0-25	Acceleration/Deceleration time base frequency	0: Maximum frequency (P0-10) 1: Set frequency 2: 100 Hz	0	★
P0-26	Base frequency for UP/DOWN modification during running	0: Running frequency 1: Set frequency	0	★
P0-27	Binding command source to frequency source	Unit's digit (Binding operation panel command to frequency source) 0: No binding 1: Frequency source by digital setting 2: AI1 3: AI2 4: Panel potentiometer external keyboard potentiometer 5: HDI Pulse setting (DI5) 6: Multi-command 7: Simple PLC 8: PID 9: Communication setting Ten's digit (Binding terminal command to frequency source) Hundred's digit (Binding communication command to frequency source)	0000	☆
P1 Motor Parameters				
P1-00	Motor type selection	0: Common asynchronous motor 2: Permanent magnetic synchronous motor	0	★
P1-01	Rated motor power	0.1kW ~ 1000.0kW	Model dependent	★
P1-02	Rated motor voltage	1V ~ 2000V	Model dependent	★
P1-03	Rated motor current	0.01A ~ 25.00A(AC drive power≤11kW)	Model dependent	★
P1-04	Rated motor frequency	0.01Hz ~ maximum frequency	Model dependent	★
P1-05	Rated motor rotational speed	1rpm ~ 65535rpm	Model dependent	★

MANUAL

Function Code	Parameter Name	Setting Range	Default	Property
P1-10	No-load current (asynchronous motor)	0.01A~P1-03	Model dependent	★
P1-37	Auto-tuning selection	0: No auto-tuning 1: Asynchronous motor static auto-tuning 2: Asynchronous motor complete auto-tuning	0	★
P2 Vector Control Parameters				
P2-00	Speed loop proportional gain 1	1 ~ 100	30	☆
P2-01	Speed loop integral time 1	0.01s ~ 10.00s	0.50s	☆
P2-02	Switchover frequency 1	0.00 ~ P2-05	5.00Hz	☆
P2-03	Speed loop proportional gain 2	1 ~ 100	20	☆
P2-04	Speed loop integral time 2	0.01s ~ 10.00s	1.00s	☆
P2-05	Switchover frequency 2	P2-02 ~ maximum output frequency	10.00Hz	☆
P2-06	Vector control slip gain	50% ~ 200%	100%	☆
P2-07	Time constant of speed loop filter	0.000s ~ 1.000s	0.050s	☆
P2-09	Torque upper limit source in speed control mode	0: Function code setting at P2-10 1: AI1 2: AI2 3: Panel potentiometer external keyboard potentiometer 4: HDI Pulse setting 5: Communication setting 6: MIN(AI1,AI2) 7: MAX(AI1,AI2) 1-7 The full range of options corresponds to P2-10	0	☆
P2-10	Digital setting of torque upper limit in speed control mode	0.0% ~ 200.0%	150.0%	☆
P2-13	Excitation adjustment proportional gain	0 ~ 60000	2000	☆
P2-14	Excitation adjustment integral gain	0 ~ 60000	1300	☆
P2-15	Torque adjustment proportional gain	0 ~ 60000	2000	☆
P2-16	Torque adjustment integral gain	0 ~ 60000	1300	☆
P2-17	Speed loop integral property	Unit's digit: integral separation 0: Disabled 1: Enabled	0	☆

MANUAL

Function Code	Parameter Name	Setting Range	Default	Property
P2-20	Maximum output voltage coefficient	100% ~ 110%	105%	★
P2-21	Maximum torque coefficient in weak magnetic field	50% ~ 200%	100%	☆
P3 V/F Control Parameters				
P3-00	V/F curve setting	0: Linear V/F 1: Multi-point V/F 2: Square V/F 3: 1.2 power V/F 4: 1.4 power V/F 6: 1.6 power V/F 8: 1.8 power V/F 9: Reserved 10: V/F complete separation 11: V/F half separation	0	★
P3-01	Torque boost	0.0%: (Automatic torque boost) 0.1% ~ 30.0%	Model dependent	☆
P3-02	Cut-off frequency of torque boost	0.00Hz ~ maximum frequency	50.00Hz	★
P3-03	Multi-point V/F frequency 1	0.00Hz ~ P3-05	0.00Hz	★
P3-04	Multi-point V/F voltage 1	0.0% ~ 100.0%	0.0%	★
P3-05	Multi-point V/F frequency 2	P3-03 ~ P3-07	0.00Hz	★
P3-06	Multi-point V/F voltage 2	0.0% ~ 100.0%	0.0%	★
P3-07	Multi-point V/F frequency 3	P3-05 ~ rated motor frequency (P1-04)	0.00Hz	★
P3-08	Multi-point V/F voltage 3	0.0% ~ 100.0%	0.0%	★
P3-09	V/F slip compensation gain	0.0% ~ 200.0%	0.0%	☆
P3-10	V/F over-excitation gain	0 ~ 200	64	☆
P3-11	V/F oscillation suppression gain	0 ~ 100	Model dependent	☆

MANUAL

Function Code	Parameter Name	Setting Range	Default	Property
P4 Input Terminals				
P4-00	DI1 terminal function selection	0: No function 1: Forward RUN (FWD) or RUN 2: Reverse RUN (REV) or RUN direction 3: Three-line control 4: Forward JOG (FJOG) 5: Reverse JOG (RJOG) 6: Terminal UP 7: Terminal DOWN 8: Coast to stop 9: Fault reset (RESET) 10: RUN pause	1	★
P4-01	DI2 terminal function selection	11: Normally open (NO) input of external fault 12: Multi-reference terminal 1 13: Multi-reference terminal 2 14: Multi-reference terminal 3 15: Multi-reference terminal 4 16: Terminal 1 for acceleration/ deceleration time selection 17: Terminal 2 for acceleration/ deceleration time selection	2	★
P4-02	DI3 terminal function selection	18: Frequency source switchover 19: UP and DOWN setting clear (terminal, operation panel) 20: Command source switchover terminal 1 21: Acceleration/Deceleration prohibited 22: PID pause 23: PLC status reset 24: Swing pause 25: Counter input	4	★
P4-03	DI4 terminal function selection	26: Counter reset 27: Length count input 28: Length reset 29: Torque control prohibited 30: Pulse input (enabled only for DI5) 31: Reserved 32: Immediate DC braking 33: Normally closed (NC) input of external fault	9	★
P4-04	DI5 terminal function selection	34: Frequency modification enable 35: Reverse PID action direction 36: External STOP terminal 1 37: Command source switchover terminal 2	12	★

MANUAL

		38: PID integral pause 39: Switchover between main frequency source X and preset frequency 40: Switchover between auxiliary frequency source Y and preset frequency 41: Reserved 42: Reserved 43: PID parameter switchover 44: User-defined fault 1 45: User-defined fault 2 46: Speed control/Torque control switchover 47: Emergency stop 48: External STOP terminal 2 49: Deceleration DC braking 50: Clear the current running time 51-59: Reserved		
P4-10	DI filter time	0.000s ~ 1.000s	0.01s	☆
P4-11	Terminal command mode	0: Two-line mode 1 1: Two-line mode 2 2: Three-line mode 1	1	★
P4-12	Terminal UP/DOWN rate	0.001Hz/s ~ 65.535Hz/s	1.00Hz/s	☆
P4-13	AI curve 1 minimum input	0.00V ~ P4-15	0.00V	☆
P4-14	Corresponding setting of AI curve 1 minimum input	-100.0% ~ +100.0%	0.0%	☆
P4-15	AI curve 1 maximum input	P4-13 ~ +10.00V	10.00V	☆
P4-16	Corresponding setting of AI curve 1 maximum input	-100.0% ~ +100.0%	100.0%	☆
P4-17	AI1 filter time	0.00s ~ 10.00s	0.10s	☆
P4-18	AI curve 2 minimum input	0.00V ~ P4-20	0.00V	☆
P4-19	Corresponding setting of AI curve 2 minimum input	-100.0% ~ +100.0%	0.0%	☆
P4-20	AI curve 2 maximum input	P4-18 ~ +10.00V	10.00V	☆
P4-21	Corresponding setting of AI curve 2 maximum input	-100.0% ~ +100.0%	100.0%	☆
P4-22	AI2 filter time	0.00s ~ 10.00s	0.10s	☆
P4-23	AI curve 3 minimum input	-10.00V ~ P4-25	-10.00V	☆
P4-24	Corresponding setting of AI curve 3 minimum input	-100.0% ~ +100.0%	-100.0%	☆

MANUAL

Function Code	Parameter Name	Setting Range	Default	Property
P4-25	AI curve 3 maximum input	P4-23 ~ +10.00V	10.00V	☆
P4-26	Corresponding setting of AI curve 3 maximum input	-100.0% ~ +100.0%	100.0%	☆
P4-27	Panel potentiometer filter time	0.00s ~ 10.00s	0.10s	☆
P4-28	HDI Pulse minimum input	0.00kHz ~ P4-30	0.00kHz	☆
P4-29	Corresponding setting of HDI minimum input	-100.0% ~ 100.0%	0.0%	☆
P4-30	HDI maximum input	P4-28 ~ 100.00kHz	50.00kHz	☆
P4-31	Corresponding setting of HDI pulse maximum input	-100.0% ~ 100.0%	100.0%	☆
P4-32	HDI filter time	0.00s ~ 10.00s	0.10s	☆
P4-33	AI curve selection	Unit's digit (AI1 curve selection) Curve 1 (2 points, see P4-13 to F4-16) Curve 2 (2 points, see P4-18 to F4-21) Curve 3 (2 points, see P4-23 to F4-26) Curve 4 (4 points, see A6-00 to A6-07) Curve 5 (4 points, see A6-08 to A6-15) Ten's digit (AI2 curve selection) Curve 1 to curve 5 (same as AI1) Hundred's digit (AI3 curve selection) Curve 1 to curve 5 (same as AI1)	321	☆
P4-34	Setting for AI less than minimum input	Unit's digit (Setting for AI1 less than minimum input) 0: Minimum value 1: 0.0% Ten's digit (Setting for AI2 less than minimum input) 0, 1 (same as AI1) Hundred's digit (Setting for AI3 less than minimum input) 0, 1 (same as AI1)	000	☆
P4-35	DI1 delay time	0.0s ~ 3600.0s	0.0s	★
P4-36	DI2 delay time	0.0s ~ 3600.0s	0.0s	★
P4-37	DI3 delay time	0.0s ~ 3600.0s	0.0s	★

MANUAL

Function Code	Parameter Name	Setting Range	Default	Property
P4-38	DI valid mode selection 1	0: High level valid 1: Low level valid Unit's digit (DI1 valid mode) Ten's digit (DI2 valid mode) Hundred's digit (DI3 valid mode) Thousand's digit (DI4 valid mode) Ten thousand's digit (DI5 valid mode)	00000	★
P4-39	AI1 input voltage/current selection	0: Voltage input 1: Current input	0	★
P5 Output Terminals				
P5-00	FM terminal output mode	0: Pulse output (FMP) 1: Switch signal output (FMR)	0	☆
P5-01	FMR output function selection	0: No output 1: AC drive running 2: Fault output (stop) 3: Frequency-level detection FDT1 output 4: Frequency reached 5: Zero-speed running (no output at stop) 6: Motor overload pre-warning 7: AC drive overload pre-warning 8: Set count value reached 9: Designated count value reached 10: Length reached 11: PLC cycle complete 12: Accumulative running time reached 13: Frequency limited 14: Torque limited 15: Ready for RUN	2	☆
P5-02	Relay function (T/A-T/B-T/C)	16: AI1 > AI2 17: Frequency upper limit reached 18: Frequency lower limit reached(operation related) 19: Undervoltage state output 20: Communication setting 21: Reserved 22: Reserved 23: Zero-speed running 2 (having output at stop) 24: Accumulative power-on time reached 25: Frequency level detection FDT2 output 26: Frequency 1 reached output 27: Frequency 2 reached output 28: Current 1 reached output 29: Current 2 reached output 30: Timing reached output	0	☆
			1	☆

MANUAL

		31: All input limit exceeded 32: Load becoming 0 33: Reverse running 34: Zero current state 35: IGBT temperature reached 36: Current limit exceeded 37: Frequency lower limit reached(having output at stop) 38: Alarm output 39: Motor overheat warning 40: Current running time reached 41: Fault output (There is no output if it is the coast to stop fault and undervoltage occurs.)		
P5-06	FMP output function selection	0: Running frequency 1: Set frequency 2: Output current 3: Output torque (absolute value) 4: Output power 5: Output voltage 6: HDI input(100.0% corresponds 100.0kHz)	0	☆
P5-08	AOI output function selection	7: AI1 8: AI2 11: Count value 12: Communication setting 13: Motor rotational speed 14: Output current(100.0% corresponds 1000.0A) 15: Output voltage(100.0% corresponds 1000.0V) 16: Output torque (actual value)	0	☆
P5-09	Maximum FMP output	0.01kHz ~ 100.00kHz	50.00kHz	☆
P5-12	AOI offset coefficient	-100.0% ~ +100.0%	0.0%	☆
P5-13	AOI gain	-10.00 ~ +10.00	1.00	☆
P5-17	FMR output delay time	0.0s ~ 3600.0s	0.0s	☆
P5-18	Relay 1 output delay time	0.0s ~ 3600.0s	0.0s	☆
P5-19	Relay 2 output delay time	0.0s ~ 3600.0s	0.0s	☆
P5-20	DO1 output delay time	0.0s ~ 3600.0s	0.0s	☆
P6 Start/Stop Control				
P6-00	Start mode	0: Direct start 1: Rotational speed tracking restart 2: Pre-excited start (asynchronous motor)	0	☆

MANUAL

Function Code	Parameter Name	Setting Range	Default	Property
P6-01	Rotational speed tracking mode	0: From frequency at stop 1: From power frequency 2: From maximum frequency	0	★
P6-02	Rotational speed tracking speed	1 ~ 100	20	☆
P6-03	Startup frequency	0.00Hz ~ 10.00Hz	0.00Hz	☆
P6-04	Startup frequency holding time	0.0s ~ 100.0s	0.0s	★
P6-05	Startup DC braking current/ Pre-excited current	0% ~ 100%	0%	★
P6-06	Startup DC braking time/ Pre-excited time	0.0s ~ 100.0s	0.0s	★
P6-07	Acceleration/Deceleration mode	0: Linear acceleration/ deceleration 1: Static S-curve 2: Dynamic S-curve	0	★
P6-08	Time proportion of S-curve start segment	0.0% ~ (100%-P6-09)	30.0%	★
P6-09	Time proportion of S-curve end segment	0.0% ~ (100%-P6-08)	30.0%	★
P6-10	Stop mode	0: Decelerate to stop 1: Coast to stop	0	☆
P6-11	Initial frequency of stop DC braking	0.00Hz ~ maximum frequency	0.00Hz	☆
P6-12	Waiting time of stop DC braking	0.0s ~ 100.0s	0.0s	☆
P6-13	Stop DC braking current	0% ~ 100%	0%	☆
P6-14	Stop DC braking time	0.0s ~ 100.0s	0.0s	☆
P6-15	Brake use ratio	0% ~ 100%	100%	☆
P7 Operation Panel and Display				
P7-01	MF.K Key function selection	0: MF.K key disabled 1: Switchover between operation panel control and remote command control (terminal or communication) 2: Switchover between forward rotation and reverse rotation 3: Forward JOG 4: Reverse JOG	0	★
P7-02	STOP/RESET key function	0: STOP/RESET key enabled only in operation panel control 1: STOP/RESET key enabled in any operation mode	1	☆

MANUAL

Function Code	Parameter Name	Setting Range	Default	Property
P7-03	LED display running parameters 1	0000–FFFF Bit00: Running frequency 1 (Hz) Bit01: Set frequency (Hz) Bit02: Bus voltage (V) Bit03: Output voltage (V) Bit04: Output current (A) Bit05: Output power (kW) Bit06: Output torque (%) Bit07: DI input status Bit08: DO output status Bit09: AI1 voltage (V) Bit10: AI2 voltage (V) Bit11: Panel potentiometer voltage (V) Bit12: Count value Bit13: Length value Bit14: Load speed display Bit15: PID setting	1F	☆
P7-04	LED display running parameters 2	0000–FFFF Bit00: PID feedback Bit01: PLC stage Bit02: HDI setting frequency (kHz) Bit03: Running frequency 2 (Hz) Bit04: Remaining running time Bit05: AI1 voltage before correction (V) Bit06: AI2 Bit07: Panel potentiometer voltage before correction (V) Bit08: Linear speed Bit09: Current power-on time (Hour) Bit10: Current running time (Min) Bit11: HDI setting frequency (Hz) Bit12: Communication setting value Bit13: Encoder feedback speed (Hz) Bit14: Main frequency X display (Hz) Bit15: Auxiliary frequency Y display (Hz)	0	☆
P7-05	LED display stop parameters	0000–FFFF Bit00: Set frequency (Hz) Bit01: Bus voltage (V) Bit02: DI input status Bit03: DO output status Bit04: AI1 voltage (V) Bit05: AI2 voltage (V) Bit06: Potentiometer voltage (V) Bit07: Count value Bit08: Length value Bit09: PLC stage Bit10: Load speed	33	☆

MANUAL

Function Code	Parameter Name	Setting Range	Default	Property
		Bit11: PID setting Bit12: HDI setting frequency (kHz)		
P7-06	Load speed display coefficient	0.0001 ~ 6.5000	1.0000	☆
P7-07	Heatsink temperature of AC drive IGBT	0°C ~ 120°C	-	●
P7-09	Accumulative running time	0h ~ 65535h	-	●
P7-12	Number of decimal places for load speed display	Unit'digit: U0-14 decimal number 0: 0 decimal place 1: 1 decimal place 2: 2 decimal places 3: 3 decimal places Ten'digit: U0-19/U0-29 decimal number 0: 0 decimal place 1: 1 decimal place	21	☆
P7-13	Accumulative power-on time	0 ~ 65535 h	-	●
P7-14	Accumulative power consumption	0 ~ 65535 kwh	-	●
P8 Auxiliary Functions				
P8-00	JOG running frequency	0.00Hz ~ maximum frequency	2.00Hz	☆
P8-01	JOG acceleration time	0.0s ~ 6500.0s	20.0s	☆
P8-02	JOG deceleration time	0.0s ~ 6500.0s	20.0s	☆
P8-03	Acceleration time 2	0.0s ~ 6500.0s	Model dependent	☆
P8-04	Deceleration time 2	0.0s ~ 6500.0s	Model dependent	☆
P8-05	Acceleration time 3	0.0s ~ 6500.0s	Model dependent	☆
P8-06	Deceleration time 3	0.0s ~ 6500.0s	Model dependent	☆
P8-07	Acceleration time 4	0.0s ~ 6500.0s	Model dependent	☆
P8-08	Deceleration time 4	0.0s ~ 6500.0s	Model dependent	☆
P8-09	Jump frequency 1	0.00Hz ~ maximum frequency	0.00Hz	☆
P8-10	Jump frequency 2	0.00Hz ~ maximum frequency	0.00Hz	☆
P8-11	Frequency jump amplitude	0.00Hz ~ maximum frequency	0.01Hz	☆
P8-12	Forward/Reverse rotation dead-zone time	0.0s ~ 3000.0s	0.0s	☆
P8-13	Reverse control	0: Enabled 1: Disabled	0	☆
P8-14	Running mode when set frequency lower than frequency lower limit	0: Run at frequency lower limit 1: Stop 2: Run at zero speed	0	☆

MANUAL

Function Code	Parameter Name	Setting Range	Default	Property
P8-15	Droop control	0.00Hz ~ 10.00Hz	0.00Hz	☆
P8-16	Accumulative power-on time threshold	0h ~ 65000h	0h	☆
P8-17	Accumulative running time threshold	0h ~ 65000h	0h	☆
P8-18	Startup protection	0: No 1: Yes	0	☆
P8-19	Frequency detection value (FDT1)	0.00Hz ~ maximum frequency	50.00Hz	☆
P8-20	Frequency detection hysteresis (FDT hysteresis 1)	0.0% ~ 100.0% (FDT1 electrical level)	5.0%	☆
P8-21	Detection range of frequency reached	0.0% ~ 100.0% (maximum frequency)	0.0%	☆
P8-25	Frequency switchover point between acceleration time 1 and acceleration time 2	0.00Hz ~ maximum frequency	0.00Hz	☆
P8-26	Frequency switchover point between deceleration time 1 and deceleration time 2	0.00Hz ~ maximum frequency	0.00Hz	☆
P8-27	Terminal JOG preferred	0: Disabled 1: Enabled	0	☆
P8-28	Frequency detection value (FDT2)	0.00Hz ~ maximum frequency	50.00Hz	☆
P8-29	Frequency detection hysteresis (FDT hysteresis 2)	0.0% ~ 100.0% (FDT2 electrical level)	5.0%	☆
P8-30	Any frequency reaching detection value 1	0.00Hz ~ maximum frequency	50.00Hz	☆
P8-31	Any frequency reaching detection amplitude 1	0.0% ~ 100.0% (maximum frequency)	0.0%	☆
P8-32	Any frequency reaching detection value 2	0.00Hz ~ maximum frequency	50.00Hz	☆
P8-33	Any frequency reaching detection amplitude 2	0.0% ~ 100.0% (maximum frequency)	5.0%	☆
P8-34	Zero current detection level	0.0% ~ 300.0% rated motor current	5.0%	☆
P8-35	Zero current detection delay time	0.01s ~ 600.00s	0.10s	☆
P8-36	Output overcurrent threshold	0.0% (no detection) 0.1%~300.0% (rated motor current)	200.0%	☆
P8-37	Output overcurrent detection delay time	0.00s ~ 600.00s	0.00s	☆
P8-38	Any current reaching 1	0.0%~300.0% (rated motor current)	100.0%	☆

MANUAL

Function Code	Parameter Name	Setting Range	Default	Property
P8-39	Any current reaching 1 amplitude	0.0% ~ 300.0%(rated motor current)	0.0%	☆
P8-40	Any current reaching 2	0.0% ~ 300.0%(rated motor current)	100.0%	☆
P8-41	Any current reaching 2 amplitude	0.0% ~ 300.0% (rated motor current)	0.0%	☆
P8-42	Timing function	0: Disabled 1: Enabled	0	☆
P8-43	Timing duration source	0: P8-44 1: AI1 2: AI2 3: Panel potentiometer (analog input corresponds to the value of P8-44)	0	☆
P8-44	Timing duration	0.0Min ~ 6500.0Min	0.0Min	☆
P8-45	AI1 input voltage lower limit	0.00V ~ P8-46	3.10V	☆
P8-46	AI1 input voltage upper limit	P8-45 ~ 10.00V	6.80V	☆
P8-47	IGBT temperature threshold	0°C ~ 100°C	75°C	☆
P8-49	Wakeup frequency	Dormant frequency (P8-51) ~ maximum frequency (P0-10)	0.00Hz	☆
P8-50	Wakeup delay time	0.0s ~ 6500.0s	0.0s	☆
P8-51	Dormant frequency	0.00Hz ~ wakeup frequency (P8-49)	0.00Hz	☆
P8-52	Dormant delay time	0.0s ~ 6500.0s	0.0s	☆
P8-53	Current running time reached	0.0 ~ 6500.0 min	0.0Min	☆
P8-54	Output power correction coefficient	0.00% ~ 200.0%	100.0%	☆
P9 Fault and Protection				
P9-00	Motor overload protection selection	0: Disabled 1: Enabled	1	●
P9-01	Motor overload protection	0.20 ~ 10.00	1.00	●
P9-02	Motor overload warning coefficient	50% ~ 100%	80%	●
P9-03	Overvoltage stall gain	0 ~ 100	0	●
P9-04	Overvoltage stall protective voltage	650 ~ 780V	760V	●
P9-05	Overcurrent stall gain	0 ~ 100	20	●
P9-06	Overcurrent stall protective current	100% ~ 200%	150%	●
P9-07	Short-circuit to ground upon power-on	0: Disabled 1: Enabled	1	●
P9-08	Brake unit action starting voltage	700 ~ 800V	750V	●

MANUAL

Function Code	Parameter Name	Setting Range	Default	Property
P9-09	Fault auto reset times	0 ~ 20	0	●
P9-10	DO action during fault auto reset	0: Not act 1: Act	0	●
P9-11	Time interval of fault auto reset	0.1s ~ 100.0s	1.0s	●
P9-12	Input phase loss protection/ contactor energizing protection selection	Unit's digit: Input phase loss protection Ten's digit: Contactor energizing protection 0: Disabled 1: Enabled	11	●
P9-13	Output phase loss protection selection	0: Disabled 1: Enabled	1	●
P9-14	1 st fault type	0: No fault 1: Reserved 2: Overcurrent during acceleration 3: Overcurrent during deceleration 4: Overcurrent at constant speed 5: Overvoltage during acceleration 6: Overvoltage during deceleration 7: Overvoltage at constant speed 8: Buffer resistance overload 9: Undervoltage 10: AC drive overload 11: Motor overload	-	●
P9-15	2 nd fault type	12: Power input phase loss 13: Power output phase loss 14: IGBT overheat 15: External equipment fault 16: Communication fault 17: Contactor fault 18: Current detection fault 19: Motor auto-tuning fault 21: EEPROM read-write fault 22: AC drive hardware fault 23: Short circuit to ground	-	●
P9-16	3 rd (latest) fault type	24: Reserved 25: Reserved 26: Accumulative running time reached 27: User-defined fault 1 28: User-defined fault 2 29: Accumulative power-on time reached 30: Load becoming 0 31: PID feedback lost during running 40: Current limit fault 41: Motor switchover fault during running 42: Too large speed deviation 43: Motor over-speed	-	●

MANUAL

Function Code	Parameter Name	Setting Range	Default	Property
P9-17	Frequency upon 3 rd fault	—	-	●
P9-18	Current upon 3 rd fault	—	-	●
P9-19	Bus voltage upon 3 rd fault	—	-	●
P9-20	Input terminal status upon 3 rd fault	—	-	●
P9-21	Output terminal status upon 3 rd fault	—	-	●
P9-22	AC drive status upon 3 rd fault	—	-	●
P9-23	Power-on time upon 3 rd fault	—	-	●
P9-24	Running time upon 3 rd fault	—	-	●
P9-27	Frequency upon 2 nd fault	—	-	●
P9-28	Current upon 2 nd fault	—	-	●
P9-29	Bus voltage upon 2 nd fault	—	-	●
P9-30	Input terminal status upon 2 nd fault	—	-	●
P9-31	Output terminal status upon 2 nd fault	—	-	●
P9-32	AC drive status upon 2 nd fault	—	-	●
P9-33	Power on time upon 2 nd fault	—	-	●
P9-34	Running time upon 2 nd fault	—	-	●
P9-37	Frequency upon 1 st fault	—	-	●
P9-38	Current upon 1 st fault	—	-	●
P9-39	Bus voltage upon 1 st fault	—	-	●
P9-40	Input terminal status upon 1 st fault	—	-	●
P9-41	Output terminal status upon 1 st fault	—	-	●
P9-42	AC drive status upon 1 st fault	—	-	●
P9-43	Power-on time upon 1 st fault	—	-	●
P9-44	Running time upon 1 st fault	—	-	●
P9-47	Fault protection action selection 1	Unit's digit (Motor overload, 11) 0: Coast to stop 1: Stop according to the stop mode 2: Continue to run Ten's digit (Power input phase loss, 12) Hundred's digit (Power output phase loss, 13)	00000	☆

MANUAL

Function Code	Parameter Name	Setting Range	Default	Property
		Thousand's digit (External equipment fault, 15) Ten thousand's digit (Communication fault, 16)		
P9-54	Frequency selection for continuing to run upon fault	0: Current running frequency 1: Set frequency 2: Frequency upper limit 3: Frequency lower limit 4: Backup frequency upon abnormality	00000	☆
P9-55	Backup frequency upon abnormality	0.0% ~ 100.0% (100.0% corresponds to maximum frequency P0-10)	100.0%	☆
P9-59	Action selection at instantaneous power failure	0: Invalid 1: Bus voltage constant control 2: Decelerate to stop	0	★
P9-60	Action pause judging voltage at instantaneous power failure	80% ~ 100.0%	85.0%	★
P9-61	Voltage rally judging time at instantaneous power failure	0.5s	0.5s	★
P9-62	Action judging bus voltage at instantaneous power failure	80% ~ 100.0%	80.0%	★
P9-63	Protection upon load becoming 0	0: Disabled 1: Enabled	0	☆
P9-64	Detection level of load becoming 0	0.0 ~ 100.0%	10.0%	☆
P9-65	Detection time of load becoming 0	0.0 ~ 60.0s	1.0s	☆
PA PID Function				
PA-00	PID setting source	0: PA-01 1: AI1 2: AI2 3: Panel potentiometer 4: HDI Pulse setting (DI5) 5: Communication setting 6: Multi-reference	0	☆
PA-01	PID digital setting	0.0% ~ 100.0%	50.0%	☆
PA-02	PID feedback source	0: AI1 1: AI2 2: Panel potentiometer 3: AI1 - AI2 4: HDI Pulse setting (DI5) 5: Communication setting 6: AI1 + AI2 7: MAX (AI1 , AI2) 8: MIN (AI1 , AI2)	0	☆

MANUAL

Function Code	Parameter Name	Setting Range	Default	Property
PA-03	PID action direction	0: Forward action 1: Reverse action	0	☆
PA-04	PID setting feedback range	0 ~ 65535	1000	☆
PA-05	Proportional gain Kp1	0.0 ~ 100.0	20.0	☆
PA-06	Integral time Ti1	0.01s ~ 10.00s	2.00s	☆
PA-07	Differential time Td1	0.000s ~ 10.000s	0.000s	☆
PA-08	Cut-off frequency of PID reverse rotation	0.00 ~ maximum frequency	2.00Hz	☆
PA-09	PID deviation limit	0.0% ~ 100.0%	0.0%	☆
PA-10	PID differential limit	0.00% ~ 100.00%	0.10%	☆
PA-11	PID setting change time	0.00 ~ 650.00s	0.00s	☆
PA-12	PID feedback filter time	0.00 ~ 60.00s	0.00s	☆
PA-13	PID output filter time	0.00 ~ 60.00s	0.00s	☆
PA-15	Proportional gain Kp2	0.0 ~ 100.0	20.0	☆
PA-16	Integral time Ti2	0.01s ~ 10.00s	2.00s	☆
PA-17	Differential time Td2	0.000s ~ 10.000s	0.000s	☆
PA-18	PID parameter switchover condition	0: No switchover 1: Switchover via DI 2: Automatic switchover based on Deviation 3: Automatic switchover based on running frequency	0	☆
PA-19	PID parameter switchover deviation 1	0.0% ~ PA-20	20.0%	☆
PA-20	PID parameter switchover deviation 2	PA-19 ~ 100.0%	80.0%	☆
PA-21	PID initial value	0.0% ~ 100.0%	0.0%	☆
PA-22	PID initial value holding time	0.00 ~ 650.00s	0.00s	☆
PA-23	Maximum deviation between two PID outputs in forward direction	0.00% ~ 100.00%	1.00%	☆
PA-24	Maximum deviation between two PID outputs in reverse direction	0.00% ~ 100.00%	1.00%	☆
PA-25	PID integral property	Unit's digit (Integral separated) 0: Invalid 1: Valid Ten's digit (Whether to stop	00	☆

MANUAL

Function Code	Parameter Name	Setting Range	Default	Property
		integral operation when the output reaches the limit) 0: Continue integral operation 1: Stop integral operation		
PA-26	Detection value of PID feedback loss	0.0%: Not judging feedback loss 0.1%~100.0%	0.0%	☆
PA-27	Detection time of PID feedback loss	0.0s ~ 20.0s	0.0s	☆
PA-28	PID operation at stop	0: No PID operation at stop 1: PID operation at stop	0	☆
PB Swing Frequency, Fixed Length and Count				
PB-00	Swing frequency setting mode	0: Relative to the central frequency 1: Relative to the maximum frequency	0	☆
PB-01	Swing frequency amplitude	0.0% ~ 100.0%	0.0%	☆
PB-02	Jump frequency amplitude	0.0% ~ 50.0%	0.0%	☆
PB-03	Swing frequency cycle	0.1s ~ 3000.0s	10.0s	☆
PB-04	Triangular wave rising time coefficient	0.1% ~ 100.0%	50.0%	☆
PB-05	Set length	0m ~ 65535m	1000m	☆
PB-06	Actual length	0m ~ 65535m	0m	☆
PB-07	Number of pulses per meter	0.1 ~ 6553.5	100.0	☆
PB-08	Set count value	1 ~ 65535	1000	☆
PB-09	Designated count value	1 ~ 65535	1000	☆
PC Multi-Reference and Simple PLC Function				
PC-00	Reference 0	-100.0% ~ 100.0%	0.0%	☆
PC-01	Reference 1	-100.0% ~ 100.0%	0.0%	☆
PC-02	Reference 2	-100.0% ~ 100.0%	0.0%	☆
PC-03	Reference 3	-100.0% ~ 100.0%	0.0%	☆
PC-04	Reference 4	-100.0% ~ 100.0%	0.0%	☆
PC-05	Reference 5	-100.0% ~ 100.0%	0.0%	☆
PC-06	Reference 6	-100.0% ~ 100.0%	0.0%	☆
PC-07	Reference 7	-100.0% ~ 100.0%	0.0%	☆
PC-08	Reference 8	-100.0% ~ 100.0%	0.0%	☆
PC-09	Reference 9	-100.0% ~ 100.0%	0.0%	☆
PC-10	Reference 10	-100.0% ~ 100.0%	0.0%	☆
PC-11	Reference 11	-100.0% ~ 100.0%	0.0%	☆

MANUAL

Function Code	Parameter Name	Setting Range	Default	Property
PC-12	Reference 12	-100.0% ~ 100.0%	0.0%	☆
PC-13	Reference 13	-100.0% ~ 100.0%	0.0%	☆
PC-14	Reference 14	-100.0% ~ 100.0%	0.0%	☆
PC-15	Reference 15	-100.0% ~ 100.0%	0.0%	☆
PC-16	Simple PLC running mode	0: Stop after the AC drive runs one cycle 1: Keep final values after the AC drive runs one cycle 2: Repeat after the AC drive runs one cycle	0	☆
PC-17	Simple PLC retentive selection	Unit's digit (Retentive upon power failure) 0: No 1: Yes Ten's digit (Retentive upon stop) 0: No 1: Yes	00	☆
PC-18	Running time of simple PLC reference 0	0.0s(h) ~ 6553.5s(h)	0.0s(h)	☆
PC-19	Acceleration/deceleration time of simple PLC reference 0	0 ~ 3	0	☆
PC-20	Running time of simple PLC reference 1	0.0s(h) ~ 6553.5s(h)	0.0s(h)	☆
PC-21	Acceleration/deceleration time of simple PLC reference 1	0 ~ 3	0	☆
PC-22	Running time of simple PLC reference 2	0.0s(h) ~ 6553.5s(h)	0.0s(h)	☆
PC-23	Acceleration/deceleration time of simple PLC reference 2	0 ~ 3	0	☆
PC-24	Running time of simple PLC reference 3	0.0s(h) ~ 6553.5s(h)	0.0s(h)	☆
PC-25	Acceleration/deceleration time of simple PLC reference 3	0 ~ 3	0	☆
PC-26	Running time of simple PLC reference 4	0.0s(h) ~ 6553.5s(h)	0.0s(h)	☆
PC-27	Acceleration/deceleration time of simple PLC reference 4	0 ~ 3	0	☆
PC-28	Running time of simple PLC reference 5	0.0s(h) ~ 6553.5s(h)	0.0s(h)	☆
PC-29	Acceleration/deceleration time of simple PLC reference 5	0 ~ 3	0	☆
PC-30	Running time of simple PLC reference 6	0.0s(h) ~ 6553.5s(h)	0.0s(h)	☆
PC-31	Acceleration/deceleration time of simple PLC reference 6	0 ~ 3	0	☆

MANUAL

Function Code	Parameter Name	Setting Range	Default	Property
PC-32	Running time of simple PLC reference 7	0.0s(h) ~ 6553.5s(h)	0.0s(h)	☆
PC-33	Acceleration/deceleration time of simple PLC reference 7	0 ~ 3	0	☆
PC-34	Running time of simple PLC reference 8	0.0s(h) ~ 6553.5s(h)	0.0s(h)	☆
PC-35	Acceleration/deceleration time of simple PLC reference 8	0 ~ 3	0	☆
PC-36	Running time of simple PLC reference 9	0.0s(h) ~ 6553.5s(h)	0.0s(h)	☆
PC-37	Acceleration/deceleration time of simple PLC reference 9	0 ~ 3	0	☆
PC-38	Running time of simple PLC reference 10	0.0s(h) ~ 6553.5s(h)	0.0s(h)	☆
PC-39	Acceleration/deceleration time of simple PLC reference 10	0 ~ 3	0	☆
PC-40	Running time of simple PLC reference 11	0.0s(h) ~ 6553.5s(h)	0.0s(h)	☆
PC-41	Acceleration/deceleration time of simple PLC reference 11	0 ~ 3	0	☆
PC-42	Running time of simple PLC reference 12	0.0s(h) ~ 6553.5s(h)	0.0s(h)	☆
PC-43	Acceleration/deceleration time of simple PLC reference 12	0 ~ 3	0	☆
PC-44	Running time of simple PLC reference 13	0.0s(h) ~ 6553.5s(h)	0.0s(h)	☆
PC-45	Acceleration/deceleration time of simple PLC reference 13	0 ~ 3	0	☆
PC-46	Running time of simple PLC reference 14	0.0s(h) ~ 6553.5s(h)	0.0s(h)	☆
PC-47	Acceleration/deceleration time of simple PLC reference 14	0 ~ 3	0	☆
PC-48	Running time of simple PLC reference 15	0.0s(h) ~ 6553.5s(h)	0.0s(h)	☆
PC-49	Acceleration/deceleration time of simple PLC reference 15	0 ~ 3	0	☆
PC-50	Time unit of simple PLC running	0: second 1: hour	0	☆
PC-51	Reference 0 source	0: Set by PC-00 1: AI1 2: AI2 3: Panel potentiometer 4: HDI pulse setting 5: PID 6: Set by preset frequency (P0-08), modified via UP/DOWN	0	☆

MANUAL

Function Code	Parameter Name	Setting Range	Default	Property
PD Communication Parameters				
PD-00	Baud rate	Unit's digit: MODBUS 0: 300BPS 1: 600BPS 2: 1200BPS 3: 2400BPS 4: 4800BPS 5: 9600BPS 6: 19200BPS 7: 38400BPS 8: 57600BPS 9: 115200BPS Ten's digit: PROFIBUS-DP 0: 115200 BPs 1: 208300 BPs 2: 256000 BPs 3: 512000 Bps Hundred's digit: (reserved) Thousand's digit: CANlink 0: 20 1: 50 2: 100 3: 125 4: 250 5: 500 6: 1M	6005	☆
PD-01	MODBUS data format	0: No check, data format <8,N,2> 1: Even parity check, data format <8,E,1> 2: Odd Parity check, data format <8,O,1> 3: No check, data format <8,N,1> Valid for Modbus	0	☆
PD-02	Local address	0: Broadcast address 1 ~ 247	1	☆
PD-03	MODBUS response delay	0 ~ 20ms	2	☆
PD-04	Communication timeout	0.0: invalid 0.1 ~ 60.0s	0.0	☆
PD-05	Modbus protocol selection and PROFIBUS-DP data format	Unit's digit: Modbus protocol 0: Non-standard Modbus protocol 1: Standard Modbus protocol Ten's digit: PROFIBUS-DP data format 0: PPO1 format 1: PPO2 format 2: PPO3 format 3: PPO5 format	30	☆

MANUAL

Function Code	Parameter Name	Setting Range	Default	Property
PD-06	Communication reading current resolution	0: 0.01A 1: 0.1A	0	☆
PP Function Code Management				
PP-00	User password	0 ~ 65535	0	☆
PP-01	Restore default settings	0: No operation 01: Restore factory settings except motor parameters 02: Clear records	0	★
PP-02	AC drive parameter display property	Unit's digit (Group U display selection) 0: Not display 1: Display Ten's digit (Group A display selection) 0: Not display 1: Display	11	★
PP-03	Individualized parameter display property	Unit's digit (User-defined parameter display selection) 0: Not display 1: Display Ten's digit (User-modified parameter display selection) 0: Not display 1: Display	00	☆
PP-04	Parameter modification property	0: Modifiable 1: Not modifiable	0	☆
A0 Torque Control Parameters				
A0-00	Speed/Torque control selection	0: Speed control 1: Torque control	0	★
A0-01	Torque setting source in torque control	0: Digital setting (A0-03) 1: AI1 2: AI2 3: Panel potentiometer 4: HDI pulse setting (DI5) 5: Communication setting 6: MIN(AI1,AI2) 7: MAX(AI1,AI2) Full range of values 1-7 corresponds to the digital setting of A0-03.	0	★
A0-03	Torque digital setting in torque control	-200.0% ~ 200.0%	150.0%	☆

MANUAL

Function Code	Parameter Name	Setting Range	Default	Property
A0-05	Forward maximum frequency in torque control	0.00Hz ~ maximum frequency	50.00Hz	☆
A0-06	Reverse maximum frequency in torque control	0.00Hz ~ maximum frequency	50.00Hz	☆
A0-07	Acceleration time in torque control	0.00s ~ 65000s	0.00s	☆
A0-08	Deceleration time in torque control	0.00s ~ 65000s	0.00s	☆
A5 Control Optimization Parameters				
A5-00	DPWM switchover frequency upper limit	5.00Hz ~ maximum frequency	8.00Hz	☆
A5-01	PWM modulation mode	0: Asynchronous modulation 1: Synchronous modulation	0	☆
A5-02	Dead zone compensation mode selection	0: No compensation 1: Compensation mode 1	1	☆
A5-03	Random PWM depth	0: Random PWM invalid 1 ~ 10: PWM carrier frequency random depth	0	☆
A5-04	Rapid current limit	0: Disabled 1: Enabled	1	☆
A5-05	Current detection compensation	0 ~ 100	5	☆
A5-06	Undervoltage threshold	210 ~ 420V	350V	☆
A5-07	SVC optimization mode selection	1: Optimization mode 1 2: Optimization mode 2	1	☆
A5-08	Dead-zone time adjustment	100% ~ 200%	150%	★
A5-09	Overvoltage threshold	200.0V ~ 2500.0V	Model dependant	★

MANUAL

Function Code	Parameter Name	Setting Range	Min. Unit	Property
U0 Monitoring Parameters				
U0-00	Running frequency (Hz)		0.01Hz	●
U0-01	Set frequency (Hz)		0.01Hz	●
U0-02	Bus voltage(V)		0.1V	●
U0-03	Output voltage(V)		1V	●
U0-04	Output current(A)		0.01A	●
U0-05	Output power(kw)		0.1kW	●
U0-06	Output torque(%)		0.1%	●
U0-07	DI input state		1	●
U0-08	DO output state		1	●
U0-09	AI1 voltage(V)		0.01V	●
U0-10	AI2 voltage(V)/current(mA)		0.01V/0.01mA	●
U0-11	Panel potentiometer voltage(V)		0.01V	●
U0-12	Count value		1	●
U0-13	Length value		1	●
U0-14	Load speed display		1	●
U0-15	PID setting		1	●
U0-16	PID feedback		1	●
U0-17	PLC stage		1	●
U0-18	HDI input pulse frequency (Hz)		0.01kHz	●
U0-19	Feedback speed (Hz)		0.01Hz	●
U0-20	Remaining running time		0.1Min	●
U0-21	AI1 voltage before correction		0.001V	●
U0-22	AI2 voltage (V)/current (mA) before correction		0.001V/0.01mA	●
U0-23	Panel potentiometer voltage before correction		0.001V	●
U0-24	Linear speed		1m/Min	●
U0-25	Accumulative power-on time		1Min	●
U0-26	Accumulative running time		0.1Min	●
U0-27	HDI pulse input frequency		1Hz	●

MANUAL

Function Code	Parameter Name	Setting Range	Min. Unit	Property
U0-28	Communication setting value		0.01%	●
U0-30	Main frequency X		0.01Hz	●
U0-31	Auxiliary frequency Y		0.01Hz	●
U0-32	Viewing any register address value		1	●
U0-35	Target torque (%)		0.1%	●
U0-36	Rotation position		1	●
U0-37	Power factor angle		0.1°	●
U0-39	Target voltage upon V/F separation		1V	●
U0-40	Output voltage upon V/F separation		1V	●
U0-41	DI state visual display		1	●
U0-42	DO state visual display		1	●
U0-43	DI function state visual display 1(function 01-40)		1	●
U0-44	DI function state visual display 2(function 41-80)		1	●
U0-45	Fault information		1	●
U0-59	Current set frequency(%)		0.01%	●
U0-60	Current running frequency(%)		0.01%	●
U0-61	AC drive running state		1	●
U0-62	Current fault code		1	●
U0-65	Torque upper limit		0.1%	●

MANUAL

Chapter 7 Maintenance and Troubleshooting

7.1 Fault Description

If fault happens during the operation of the CW100 inverter system, the inverter will stop the output immediately, and the inverter fault relay will make contact action. The inverter panel displays the fault code, the corresponding fault types and common solutions are shown in the table below. List in the form for reference only, please do not repair or modify. If unable to troubleshoot, please seek technical support from our company or product agent.

7.2 Troubleshooting List

Fault Name	Display	Possible Causes	Solutions
Inverter Unit Protection	Err01	1: The output circuit is grounded or short circuited. 2: The connecting cable of the motor is too long. 3: The IGBT overheats. 4: The internal connections become loose. 5: The main control board is faulty. 6: The drive board is faulty. 7: The AC drive IGBT is faulty.	1: Eliminate external faults. 2: Install a reactor or an output filter. 3: Check the air filter and the cooling fan. 4: Connect all cables properly. 5: Contact technical support
Overcurrent during acceleration	Err02	1: The output circuit is grounded or short circuited. 2: Motor auto-tuning is not performed. 3: The acceleration time is too short. 4: Manual torque boost or V/F curve is not appropriate. 5: The voltage is too low. 6: The startup operation is performed on the rotating motor. 7: A sudden load is added during acceleration. 8: The AC drive model is of too small power class.	1: Eliminate external faults. 2: Perform the motor autotuning. 3: Increase the acceleration time. 4: Adjust the manual torque boost or V/F curve. 5: Adjust the voltage to normal range. 6: Select rotational speed tracking restart or start the motor after it stops. 7: Remove the added load. 8: Select an AC drive of higher power class.
Overcurrent during deceleration	Err03	1: The output circuit is grounded or short circuited. 2: Motor auto-tuning is not performed. 3: The deceleration time is too short. 4: The voltage is too low. 5: A sudden load is added during deceleration. 6: The braking unit and braking	1: Eliminate external faults. 2: Perform the motor autotuning. 3: Increase the deceleration time. 4: Adjust the voltage to normal range. 5: Remove the added load. 6: Install the braking unit and braking resistor.

MANUAL

		resistor are not installed.	
Overcurrent at constant speed	Err04	<ol style="list-style-type: none"> 1: The output circuit is grounded or short circuited. 2: Motor auto-tuning is not performed. 3: The voltage is too low. 4: A sudden load is added during operation. 5: The AC drive model is of too small power class. 	<ol style="list-style-type: none"> 1: Eliminate external faults. 2: Perform the motor autotuning. 3: Adjust the voltage to normal range. 4: Remove the added load. 5: Select an AC drive of higher power class.
Overvoltage during acceleration	Err05	<ol style="list-style-type: none"> 1: The input voltage is too high. 2: An external force drives the motor during acceleration. 3: The acceleration time is too short. 4: The braking unit and braking resistor are not installed. 	<ol style="list-style-type: none"> 1: Adjust the voltage to normal range. 2: Cancel the external force or install a braking resistor. 3: Increase the acceleration time. 4: Install the braking unit and braking resistor.
Overvoltage during deceleration	Err06	<ol style="list-style-type: none"> 1: The input voltage is too high. 2: An external force drives the motor during deceleration. 3: The deceleration time is too short. 4: The braking unit and braking resistor are not installed. 	<ol style="list-style-type: none"> 1: Adjust the voltage to normal range. 2: Cancel the external force or install the braking resistor. 3: Increase the deceleration time. 4: Install the braking unit and braking resistor.
Overvoltage at constant speed	Err07	<ol style="list-style-type: none"> 1: The input voltage is too high. 2: An external force drives the motor during deceleration. 	<ol style="list-style-type: none"> 1: Adjust the voltage to normal range. 2: Cancel the external force or install the braking resistor.
Control power supply fault	Err08	The input voltage is not within the allowable range.	Adjust the input voltage to the allowable range.
Undervoltage	Err09	<ol style="list-style-type: none"> 1: Instantaneous power failure occurs on the input power supply. 2: The AC drive's input voltage is not within the allowable range. 3: The bus voltage is abnormal. 4: The rectifier bridge and buffer resistor are faulty. 5: The drive board is faulty. 6: The main control board is faulty. 	<ol style="list-style-type: none"> 1: Reset the fault. 2: Adjust the voltage to normal range. 3: Contact technical support.
AC drive overload	Err10	<ol style="list-style-type: none"> 1: The load is too heavy or locked rotor occurs on the motor. 2: The AC drive model is of too small power class. 	<ol style="list-style-type: none"> 1: Reduce the load and check the motor and mechanical condition. 2: Select an AC drive of higher power class.
Motor overload	Err11	<ol style="list-style-type: none"> 1: P9-01 is set improperly. 2: The load is too heavy or locked rotor occurs on the motor. 3: The AC drive model is of too small power class. 	<ol style="list-style-type: none"> 1: Set P9-01 correctly. 2: Reduce the load and check the motor and the mechanical condition. 3: Select an AC drive of higher power class.
Power input phase loss	Err12	<ol style="list-style-type: none"> 1: The three-phase power input is abnormal. 2: The drive board is faulty. 3: The lightning board is faulty. 	<ol style="list-style-type: none"> 1: Eliminate external faults. 2: Contact technical support.

MANUAL

		4: The main control board is faulty.	
Power output phase loss	Err13	1: The cable connecting the AC drive and the motor is faulty. 2: The AC drive's three-phase outputs are unbalanced when the motor is running. 3: The drive board is faulty. 4: The IGBT is faulty.	1: Eliminate external faults. 2: Check whether the motor three-phase winding is normal. 3: Contact technical support.
IGBT overheat	Err14	1: The ambient temperature is too high. 2: The air filter is blocked. 3: The fan is damaged. 4: The thermally sensitive resistor of the IGBT is damaged. 5: The AC drive IGBT is damaged.	1: Lower the ambient temperature. 2: Clean the air filter. 3: Replace the damaged fan. 4: Replace the damaged thermally sensitive resistor. 5: Replace the AC drive IGBT.
External equipment fault	Err15	1: External fault signal is input via DI. 2: External fault signal is input via virtual I/O.	Reset the operation.
Communication fault	Err16	1: The host computer is in abnormal state. 2: The communication cable is faulty. 3: The communication parameters in group PD are set improperly.	1: Check the cabling of host computer. 2: Check the communication cabling. 3: Set the communication parameters properly.
Contactors fault	Err17	1: The drive board and power supply are faulty. 2: The contactor is faulty.	1: Replace the faulty drive board or power supply board. 2: Replace the faulty contactor.
Current detection fault	Err18	1: The HALL device is faulty. 2: The drive board is faulty.	1: Replace the faulty HALL device. 2: Replace the faulty drive board.
Motor auto-tuning fault	Err19	1: The motor parameters are not set according to the nameplate. 2: The motor auto-tuning times out.	1: Set the motor parameters according to the nameplate properly. 2: Check the cable connecting the AC drive and the motor.
EEPROM readwrite fault	Err21	The EEPROM chip is damaged.	Replace the main control board.
AC drive hardware fault	Err22	1: Overvoltage exists. 2: Overcurrent exists.	1: Handle based on overvoltage. 2: Handle based on overcurrent.
Short circuit to ground	Err23	The motor is short circuited to the ground.	Replace the cable or motor.
Accumulative running time reached	Err26	The accumulative running time reaches the setting value.	Clear the record through the parameter initialization function.

MANUAL

User-defined fault 1	Err27	1: The user-defined fault 1 signal is input via DI. 2: User-defined fault 1 signal is input via virtual I/O.	Reset the operation.
User-defined fault 2	Err28	1: The user-defined fault 2 signal is input via DI. 2: The user-defined fault 2 signal is input via virtual I/O.	Reset the operation.
Accumulative power-on time reached	Err29	The accumulative power-on time reaches the setting value.	Clear the record through the parameter initialization function.
Load becoming 0	Err30	The AC drive running current is lower than P9-64.	Check that the load is disconnected or the setting of P9-64 and P9-65 is correct.
PID feedback lost during running	Err31	The PID feedback is lower than the setting of PA-26.	Check the PID feedback signal or set PA-26 to a proper value.
Pulse-by-pulse current limit fault	Err40	1: The load is too heavy or locked rotor occurs on the motor. 2: The AC drive model is of too small power class.	1: Reduce the load and check the motor and mechanical condition. 2: Select an AC drive of higher power class.
Motor switchover fault during running	Err41	Change the selection of the motor via terminal during running of the AC drive.	Perform motor switchover after the AC drive stops.
Motor overheat	Err45	1: The cabling of the temperature sensor becomes loose. 2: The motor temperature is too high.	1: Check the temperature sensor cabling and eliminate the cabling fault. 2: Lower the carrier frequency or adopt other heat radiation measures.
Initial position fault	Err51	The motor parameters are not set based on the actual situation.	Check that the motor parameters are set correctly and whether the setting of rated current is too small.

7.3 Troubleshooting

1	No display at power-on.	1: There is no power supply to the AC drive or the power input to the AC drive is too low. 2: The power supply of the switch on the drive board of the AC drive is faulty. 3: The rectifier bridge is damaged. 4: Inverter buffer resistance damage. 5: The control board or the operation panel is faulty. 6: The cable connecting the control board and the drive board and the	1: Check the power supply. 2: Check the bus voltage. 3: Re-connect the 8-core and 28-core cables. 4: Contact technical support.
---	-------------------------	--	--

MANUAL

		operation panel breaks.	
2	"100" is displayed at power-on.	1: The cable between the drive board and the control board is in poor contact. 2: Related components on the control board are damaged. 3: The motor or the motor cable is short circuited to the ground. 4: The HALL device is faulty. 5: The power input to the AC drive is too low.	1: Re-connect the 8-core and 28-core cables. 2: Contact technical support.
3	"Err23" is displayed at power-on.	1: The motor or the motor output cable is short-circuited to the ground. 2: The AC drive is damaged.	1: Measure the insulation of the motor and the output cable with a megger. 2: Contact technical support.
4	The AC drive display is normal upon power on. But "100" is displayed after running and stops immediately.	1: The cooling fan is damaged or locked-rotor occurs. 2: The external control terminal cable is short circuited.	1: Replace the damaged fan. 2: Eliminate external fault.
5	Err14 (IGBT overheat) fault is reported frequently.	1: The setting of carrier frequency is too high. 2: The cooling fan is damaged, or the air filter is blocked. 3: Components inside the AC drive are damaged (thermal coupler or others).	1: Reduce the carrier frequency(P0-15). 2: Replace the fan and clean the air filter. 3: Contact technical support.
6	The motor does not rotate after the AC drive runs.	1: Check the motor and the motor cables. 2: The AC drive parameters are set improperly (motor parameters). 3: The cable between the drive board and the control board is in poor contact. 4: The drive board is faulty.	1: Ensure the cable between the AC drive and the motor is normal. 2: Replace the motor or clear mechanical faults. 3: Check and re-set motor parameters.
7	The AC drive reports overcurrent and overvoltage frequently.	1: The motor parameters are set improperly. 2: The acceleration/deceleration time is improper. 3: The load fluctuates.	1: Re-set motor parameters or re-perform the motor autotuning. 2: Set proper acceleration/deceleration time. 3: Contact technical support.
8	No display upon power-on.	Related component on the control board is damaged.	Replace the control board.

MANUAL

7.4 Recommended Braking Resistance Specification

VFD Model	VFD Specification	Recommended Power	Recommended Resistance	Braking Unit	Remark
Single phase 220V input, three phase 220V output					
CW100-S0.7GB	0.75KW 220V	80W	$\geq 150 \Omega$	Built-in(standard)	No special description
CW100-S1.5GB	1.5KW 220V	100W	$\geq 100 \Omega$		
CW100-S2.2GB	2.2KW 220V	100W	$\geq 70 \Omega$		
CW100-S4.0GB	3.7KW 220V	400W	$\geq 45 \Omega$		
Three phase 380V input, three phase 380V output					
CW100-T0.7GB	0.75KW 380V	150W	$\geq 300 \Omega$	Built-in(standard)	No special description
CW100-T1.5GB	1.5KW 380V	150W	$\geq 220 \Omega$		
CW100-T2.2GB	2.2KW 380V	250W	$\geq 200 \Omega$		
CW100-T4.0GB	4KW 380V	300W	$\geq 130 \Omega$		
CW100-T5.5GB	5.5KW 380V	400W	$\geq 90 \Omega$		
CW100-T7.5GB	7.5KW 380V	500W	$\geq 65 \Omega$		
CW100-T11.0GB	11KW 380V	800W	$\geq 43 \Omega$		