

◆ **Features:**

- ◇ Fast switching speed  
开关速度快
- ◇ High input impedance and low level drive  
高输入阻抗和低电平驱动
- ◇ Avalanche energy tested  
雪崩能量测试
- ◇ Improved dv/dt capability, high ruggedness  
提高 dv/dt 能力, 高耐用性

◆ **Applications**

- ◇ High efficiency switch mode power supplies  
高效率开关电源
- ◇ Power factor correction  
功率因数校正
- ◇ Electronic lamp ballast  
电子整流器



TO-247S

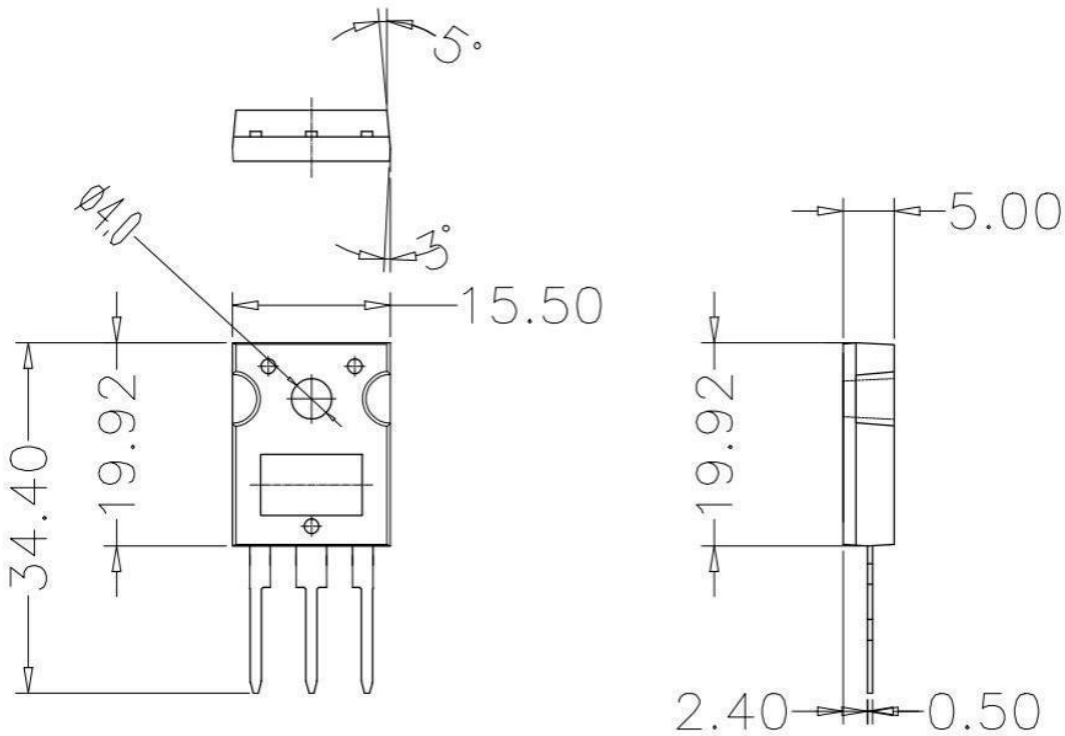
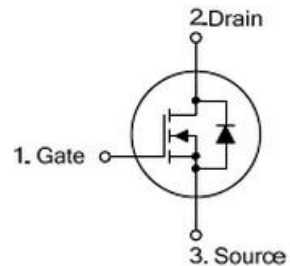
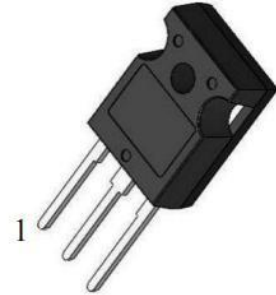



SIHG20N50C

500V N-CHANNEL MOSFET

## ◆ Absolute Maximum Ratings (Tc=25°C)

Symbol	Parameters	Ratings	Unit
V <sub>DSS</sub>	Drain-Source Voltage 漏源电压	500	V
V <sub>GS</sub>	Gate-Source Voltage-Continuous 栅源电压	±30	V
I <sub>D</sub>	Drain Current-Continuous (Note 2) 漏极持续电流	20	A
I <sub>DM</sub>	Drain Current-Single Plused (Note 1) 漏极单次脉冲电流	80	A
P <sub>D</sub>	Power Dissipation (Note 2) 功率损耗	250	W
T <sub>j</sub>	Max.Operating junction temperature 最大结温	150	°C

## ◆ Electrical characteristics (Tc=25°C unless otherwise noted)

Symbol	Parameters	Min	Typ	Max	Units	Conditions
<b>Static Characteristics</b>						
B <sub>VDSS</sub>	Drain-Source Breakdown VoltageCurrent (Note 1) 漏极击穿电压	500	--	--	V	I <sub>D</sub> =250μA, V <sub>GS</sub> =0V, T <sub>J</sub> =25°C
V <sub>GS(th)</sub>	Gate Threshold Voltage 栅极开启电压	2	--	4.0	V	V <sub>DS</sub> =V <sub>GS</sub> , I <sub>D</sub> =250μA
R <sub>DS(on)</sub>	Drain-Source On-Resistance 漏源导通电阻	--	0.23	--	Ω	V <sub>GS</sub> =10V, I <sub>D</sub> =1A
I <sub>GSS</sub>	Gate-Body Leakage Current 栅极漏电流	--	--	±100	nA	V <sub>GS</sub> =±30V, V <sub>DS</sub> =0
I <sub>DSS</sub>	Zero Gate Voltage Drain Current 零栅极电压漏极电流	--	--	1	μA	V <sub>DS</sub> =500V, V <sub>GS</sub> =0
g <sub>fs</sub>	Forward Transconductance 正向跨导	--	25	--	S	V <sub>DS</sub> =40V, I <sub>D</sub> =10A
<b>Switching Characteristics</b>						

**SIHG20N50C****500V N-CHANNEL MOSFET**

$T_{d(on)}$	Turn-On Delay Time 开启延迟时间	--	<b>95</b>	<b>220</b>	ns	$V_{DS}=250V, I_D=20A,$ $R_G=25\Omega$ (Note 2)
$T_r$	Rise Time 上升时间	--	<b>370</b>	<b>740</b>	ns	
$T_{d(off)}$	Turn-Off Delay Time 关闭延迟时间	--	<b>110</b>	<b>230</b>	ns	
$T_f$	Fall Time 下降时间	--	<b>100</b>	<b>225</b>	ns	
$Q_g$	Total Gate Charge 栅极总电荷	--	<b>45</b>	<b>62</b>	nC	$V_{DS}=480V,$ $V_{GS}=10V,$ $I_D=20A$ (Note 2)
$Q_{gs}$	Gate-Source Charge 栅源极电荷	--	<b>8.5</b>	--	nC	
$Q_{gd}$	Gate-Drain Charge 栅漏极电荷	--	<b>18.5</b>	--	nC	
<b>Dynamic Characteristics</b>						
$C_{iss}$	Input Capacitance 输入电容	--	<b>3550</b>	<b>4550</b>	pF	$V_{DS}=25V, V_{GS}=0,$ $f=1MHz$
$C_{oss}$	Output Capacitance 输出电容	--	<b>340</b>	<b>365</b>	pF	
$C_{rss}$	Reverse Transfer Capacitance 反向传输电容	--	<b>27</b>	<b>60</b>	pF	
$I_S$	Continuous Drain-Source Diode Forward Current (Note 2) 二极管导通正向持续电流	--	--	<b>20</b>	A	
$V_{SD}$	Diode Forward On-Voltage 二极管正向导通电压	--	--	<b>1.4</b>	V	$I_S=10A, V_{GS}=0$
$R_{th(j-c)}$	Thermal Resistance, Junction to Case 结到外壳的热阻	--	--	<b>0.5</b>	$^{\circ}C/W$	

Note 1: Repetitive Rating : Pulse width limited by maximum junction temperature

Note 2: Pulse test: PW  $\leq$  300us , duty cycle  $\leq$  2%.